



WÜSTHOF

Made in Solingen

CATALOGUE
2019/20

Content

14 Cutting



CONCEPT SERIES

- 14 Aeon **NEW**
- 20 Crafter
- 28 Urban Farmer

STANDARD SERIES

- 36 Epicure
- 44 Ikon
- 54 Classic Ikon
- 76 Classic
- 96 Grand Prix II
- 106 Gourmet
- 120 Silverpoint

- 132 Cleaver
- 134 Chinese chef's knives
- 136 Cheese knives
- 137 Mincing knives

- 138 **SETS**

154 Storage



- 154 Knife block-sets
- 171 Knife blocks
- 177 In-drawer knife organizer
- 178 Magnetic holder
- 180 Chef's attaché cases
- 182 Cook's cases
- 188 Blade guards

190 Sharpening



- 192 Easy Edge
- 194 Sharpening steels
- 197 Diamond & ceramic knife sharpeners
- 199 Whetstones
- 201 Knife sharpeners

210 Shears

- 210 Poultry shears
- 211 Kitchen shears
- 213 Household scissors

202 Care

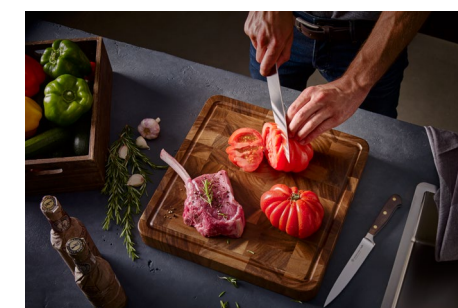

- 202 Cutting boards

214 Accessories

- 214 Forks
- 216 Spatulas
- 219 Kitchen gadgets
- 223 Spare parts

PLEASE NOTE: For production reasons, the dimensions stated in this catalogue can differ slightly. We reserve the right to make technical changes.



A family business growing with a clear strategic direction

An Interview

Harald Wüsthof (left)
Viola Wüsthof (right)

THE “NEW” WÜSTHOF

“Leading WÜSTHOF into the next generation of our family as a strong brand with a clear commitment to premium positioning and the will to grow internationally is a wonderful task, and one which we perform with passion” – this is how Harald Wüsthof and Viola Wüsthof describe the forward-looking perspective of the family business.



„What is particularly impressive in this process is the passion and pride with which the employees, some of whom have been working for us for decades, support the WÜSTHOF brand on our new path.“

1 / At WÜSTHOF, everything points to change. How are you approaching these topics?

H.W. / We – the Wüsthof family – have managed the company for more than 200 years; progressive technologies and forward-looking products have always been the guarantors of our continuous success. In recent years, in view of the changes in the market, we have also been aware of the growing importance of consistently maintaining a premium orientation for the brand, as well as that of digitisation. In order to implement these challenges consistently, we are investing heavily in strategic brand management.

2 / What is behind the name Project 8?

V.W. / Harald and I already represent the 7th generation of the family to run WÜSTHOF. Building a future-oriented perspective for the brand and thus for the next generation is a matter that is dear to the heart for both of us. We therefore want to set the course early on for the 8th Generation – and with Project 8 we have endowed this process with a name. Why? We realised that our employees need something

tangible in order to understand the process of change, which will take many years, and to implement it together with us.

3 / What brand strategy is the company following along the way to the 8th generation?

V.W. / We will position WÜSTHOF as the leading experts in cutting in the culinary world. There are no other globally significant brands which have previously made this segment their own. We therefore see precisely this focus as a powerful motor for the WÜSTHOF brand along the way to the 8th generation. To put it briefly: The new WÜSTHOF stands for cutting – no more, but also no less.

4 / What does digital transformation mean for the new WÜSTHOF?

V.W. / More than anything else, it means getting closer to the customer. For us, digital transformation means using all the possibilities of modern communication to enter into direct dialogue with the people who use our knives. In this regard, modernisation and optimisation are part of the strategy. We want to convey the delight in cutting and establish the new WÜSTHOF as the

most competent on the market for premium knives through a complete online offer of products and also various services.

5 / Premiumisation and cutting solutions for all fields of cuisine. What can the consumer expect from this?

H.W. / As a company which produces more than 90 per cent of its products in “Solingen, City of Blades” – and does so with the most modern technology and highest quality standards – we stand of course for premium concepts. We want to consistently convey this to our customers. Just as consistently, we will concentrate our offer on products which focus on cutting – in other words, primarily knives for preparing food. The range will be supplemented by offers directed at users around the themes of cutting, storage of knives, sharpening and care. This could be physical products, but also services.

6 / New target groups should be exploited. How will you address them?

V.W. / Before we determined the target groups for WÜSTHOF, we looked at the special requirements of individual consumer groups and analysed them intensively.

We then selected new focus groups accordingly and developed our products and services in such a way that the wishes of the particular group regarding the subject of cutting are entirely fulfilled. Through this structured segmentation, we are able to address people specifically about individual sales and communication channels. We will focus on personal contact with our consumers – whether directly or through digital media – in our future communication strategy.

7 / What does specialist retail mean for WÜSTHOF? Will there be new channels? And how does WÜSTHOF support sales directly at the point of sale?

H.W. / Specialist retail has always been the most important sales channel for WÜSTHOF. In this regard, competent advice for first-class knives is of incomparable value – especially in Germany. We will therefore increasingly cooperate with partners who reliably represent the high standards of our future, high-quality marketing. However, since specialist retail only represents one part of our target group, we will also increasingly use other sales channels.

We will differentiate and efficiently curate the range in each channel for the different target groups. Moreover, we are planning theme-based activities which increase frequency in all sales channels. In this way, we will make the particular point of sale more attractive again for the consumers. This means that we are not interested in working together with every retailer, but with every good retailer.

8 / The subject of internationalisation has been learned historically at WÜSTHOF. In which markets is WÜSTHOF strongest? And where is the journey going?

H.W. / Traditionally, North America – and the USA in particular – is by far the largest market for WÜSTHOF. Through consistent development of the brand, our renown and thus the awareness of our high-quality knives, has grown particularly successfully over the past few years. We want to enter into other export markets using the experiences from this success story. Besides expanding our business in Europe, Asia in particular is on the agenda – a further step in establishing a global portfolio for the company.

9 / A new vision becomes reality. What progress can you already see?

H.W. / It is amazing. Thanks to our agile structure we have been able to get strategic, organisational and operative things – which often take years in large brand product companies – off the ground in the shortest time. I’m inspired by this.

V.W. / But what is particularly impressive in this process is the passion and pride with which the employees, some of whom have been working for us for decades, support the WÜSTHOF brand on our new path.

The WÜSTHOF trident Our trademark throughout history Razor-sharp re-branding in 2019

< 1895

For around the first 80 years of its existence, two crossed arrows were used as the trademark.

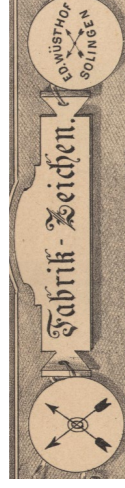

1895

Under the leadership of the 4th WÜSTHOF generation, what has now become the globally recognised “trident” made its debut, and on 9 May 1895, it was registered as a trademark in the imperial German patent office in Berlin. Since then it has become protected in almost every country in the world.



1951

The logo was redesigned at the start of the 1950s: The word “manufacturer’s mark” no longer applied and the previously grey trident was changed to a brilliant white on a black background.



1967

In the 1960s, red became the primary colour of the company: From this time, the trident stood with the tagline “Dreizack Solingen” on bright red background in a white circle. With this logo, WÜSTHOF developed into an increasingly international brand.

The red “trident” logo from Solingen, which adorns every knife, is now known around the world.



1998

In the 1990s, internationalisation proceeded further and it was decided to shift the focus from “Dreizack Solingen” to the family name WÜSTHOF. Therefore, in 1998, the family name was introduced with the trident as a new, compact word and logo.



2006

In 2006, the logo was modernised even further: The previously flat, red surface and the white trident were given a seemingly three-dimensional coat with the addition of light and shadow reflections.



2019

With a craft tradition which has developed across 200 years, WÜSTHOF is moving purposefully into the future. In doing so, the trident appears elegantly reduced and symbolises the quality without compromise of the products, while the dynamically cut shapes of the lettering signal the company’s personal skills for high-performance knives. Overall, the new design is striking and strong in character, and manages to embedden and charm customers thanks to its likeable personality. WÜSTHOF – Knives for life.



Forged knives

Precision tools for high demands

Precision-forged knives from WÜSTHOF enjoy particularly high recognition worldwide. Ambitious home cooks and seasoned pros value the premium quality and exceptional sharpness.

The knives are manufactured from one piece of stainless steel and they can be recognised from the bolster, the thicker section between the blade and handle. In our cutting-edge production, they are mostly manufactured by high tech robots and at the same time, many of the more than 55 manufacturing steps are carried out by traditional hand craft, a perfect combination with automated technology.

Glowing steel is compressed at around 1,250° Celsius and shaped in the drop forge. With the strong compression in the forge system and the subsequent unique WÜSTHOF hardening process, the steel's structure is thickened; it becomes corrosion-resistant and gains toughness and hardness. Afterwards the blank is run through the multi-level forging and buffing of the blades before the handle is assembled and the laser-controlled sharpening process (PEtec) make the forged steel into a WÜSTHOF knife of the highest quality.

Through the finely tuned design with the ergonomically designed handles and the perfectly balanced weight in the bolster, the forged knives from WÜSTHOF sit optimally in the hand and are ideal for efficient, energy-saving work.

You can of course count on consistent quality for any product from WÜSTHOF. Uncompromising quality assurance with controls in the entire production process make sure of this. This guarantees the consistently excellent standards of all knives – each one made for the perfect cut!

Laser-cut knives

Light helpers for agile work

They are lighter, but just as sharp. They are not forged, but are just as accurate. The laser-cut knives made from the WÜSTHOF forge win out with agile blades and sophisticated quality.

Since the forging process no longer applies for laser-cut knives, with about 35 manufacturing stages, the manufacturing is less expensive than for the forged kitchen tools. At the same time, more than 20 quality controls guarantee the reliable and precise performance features.

The blade blanks are cut out of a high quality steel plate using a precision laser. After that, they go through the same quality of production process as the forged knives, from hardening, grinding and buffing, to handle assembly and to the final touch.

The reduced weight, as well as the ergonomically shaped handle, allow the user to work frequently and effortlessly. Besides this, resharpening the stainless steel blades is just as effortless as for the forged knives, whereby they win out every day through their sharpness and cut quality – even after long-term use.

Overall, the agile knives not only have strong support in domestic households and professional kitchens, but also from bakers and butchers. The sum of these features underscores the extraordinary price-performance ratio of the laser-cut knife series from WÜSTHOF.

WÜSTHOF steel

The optimum formula for long-lasting sharpness

Those who decide on a WÜSTHOF knife can expect something special. The forged blade is formed from one single piece of high-quality chromium molybdenum vanadium steel with the formula for optimum sharpness: X50 Cr MoV 15. It is hardened to 58° Rockwell during the manufacturing process.

From the beginning we therefore create the basis for the most important feature of a knife – its sharpness, long-lasting robustness and ability to facilitate precise resharpening.

THE FORMULA FOR OPTIMUM SHARPNESS / X50 CR MOV 15

X	Stainless steel	Stainless steel: the base material of our knives
50	Carbon component	Amounting to 0.5% – the carbon component is important for the hardness of the blade and therefore for the sharpness of the knife.
Cr	Chromium	The additional alloy ensures a particularly high rust resistance in the finished knives.
Mo	Molybdenum	An alloy element which supports the strength and corrosion resistance of our knives.
V	Vanadium	Increases strength and toughness to reduce wear and tear on the blades.
15	Chromium content	Amounting to 15%

Precision Edge Technology

The innovative grinding technology

The most important thing for a good knife is a particularly sharp blade – both during its first use and for a long time after.

With the Precision Edge Technology (PEtec) developed by WÜSTHOF, we possess a unique process for superior blade geometry. In doing so, each individual knife is measured by a laser just before grinding. The optimum sharpening angle is calculated immediately and a precision robot sharpens the knife on the whetstone, before the knife is given its ultimate sharpness using a special buff wheel.

THE ADVANTAGES OF THE PETEC PROCESS

- Blade is extremely pointed and straight
- Extraordinarily long service life of the cutting edge
- Optimal geometry along the entire blade length
- Always consistently high and reproducible quality with extreme initial cutting performance

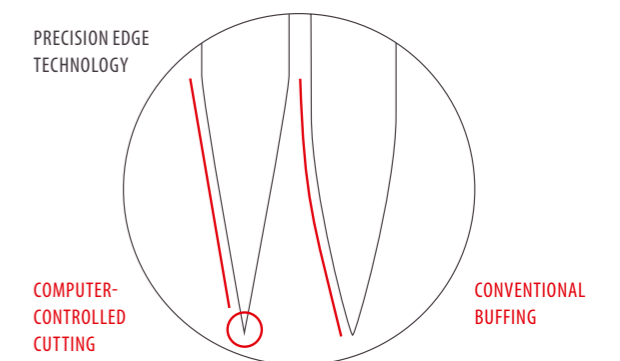

The forged Cook's knife

Multiple excellent features for optimal cutting pleasure

BLADE SURFACE

The blade is forged from one piece of stainless steel and hardened to 58° Rockwell. This makes our knives extremely sharp, robust, long-lasting and easily resharpened.

BLADE SPINE

Ground absolutely smooth, or "burred" in technical terms, a significant sign of quality. It is broader than the cutting edge and is suitable for cracking shellfish or nuts.

BOLSTER

The thickening between blade and handle is the typical feature of forged quality. The knife sits optimally in the hand thanks to the weight of the bolster.

RIVETS

Made from stainless steel and fix the handle shells securely and durably to the tang.

**Classic
Cook's knife
4582/20**



CUTTING ANGLE

The sharpness of the blade depends on the cutting angle of the grind. The smaller the angle, the sharper the blade – for most kitchen knives this is about 29°. WÜSTHOF kitchen knives are usually ground on both sides, so that they have an angle of 14.5° on each side.

GRIND (OR ALSO CUTTING EDGE)

Manufactured using the special sharpening process PEtec, it allows for long-lasting clean and precise cutting. The point is used for fine incisions. The light curve is suitable for mincing herbs. One cuts soft vegetables with the front part and hard foods are cut or chopped with the rear cutting part because the transfer of weight is greatest here, reducing your effort.

BIT

The bit is the end of the blade and if the knife has a full bolster it also protects the fingers while working.

TANG

As an extension of the blade in the knife handle, the tang gives the knife its stability, and together with the bolster ensures balance – and therefore effortless work.

HAND GUARD

The handle curves slightly into the hand so that it does not slip and the knife is always held securely.

Time is the new luxury.



Cook's knife

MAKE EACH AND EVERY MOMENT AN EXPERIENCE. WE SET NEW STANDARDS, EVERY TIME YOU USE OUR KNIVES.

WÜSTHOF Aeon brings form and function together in perfect harmony. The blades are coated with DLC (Diamond-Like Coating) resulting in durability that is as unparalleled as it is beautiful. The exquisite handles are crafted from millennia-old bog oak – each with its own certificate of authenticity. A true culinary masterpiece.

WÜSTHOF Aeon will be your signature, enabling you to capitalize on your preparation and presentation.



Aeon Cook's knife

Surface hardness:
104° Rockwell

DLC „Diamond like
Carbon“ Coating

Safe work thanks
to full bolster

Stainless steel end cap



Grind angle: 28°

Total length: 35 cm

Handle made of Bog Oak



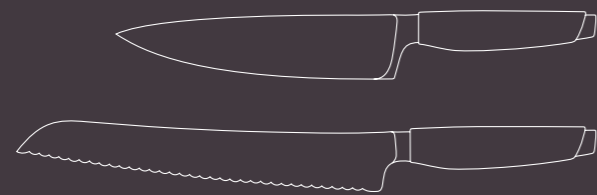

COOK'S KNIFE

WEIGHT: 250 G / BLADE LENGTH: 20 CM / BLADE WIDTH: 4,7 CM / TOTAL LENGTH: 35 CM

NEW

3685/20 / 4002293103327



SUPER SLICER

WEIGHT: 215 G / BLADE LENGTH: 26 CM / BLADE WIDTH: 4,2 CM / TOTAL LENGTH: 40 CM / WITH WAVY EDGE

NEW

3607/26 / 4002293103310



Our homage to over 200 years of knife-making tradition by WÜSTHOF



Steak knife

A MODERN POWERHOUSE FOR TRADITIONAL COOKS

Handles made from smoked oak, interlocking brass riveting, specially hardened steel for the blades: The CRAFTER series is a powerful string to the bow from more than two hundred years of knife production experience at WÜSTHOF.

As the name CRAFTER suggests, it is a robust work knife – made for unique cooks and dynamic people who are not shy of hard work, but also appreciate the stylish rustic aesthetic of this extraordinary high-quality knife.





Crafter Steak knife

Forged from one piece of stainless steel

Traditional brass rivets

Authentic trident branding

Grinding angle 30° / final buffing by hand

Handle shells made from smoked oak

Full tang



HAND GUARD

The ergonomic knife handle sits well in the hand and curves into the hand to prevent slipping. The robust handle shells are secured with traditional brass rivets.



HANDLE

The handle is made of water-resistant smoked oak, which gives the knife an unmistakable character with its individual grain as well as the authentic logo.



FULL BOLSTER

The full bolster reliably protects the fingers in everyday cooking and the balance makes agile and precision work easier.



HALF BOLSTER

The knife weighs less thanks to the slim bolster design. This allows energy-saving work. In addition, the design allows the entire blade to be used and resharpened.



FULL TANG

As an extension of the blade, the tang gives the forged knife a reliable stability. In addition, it ensures good balance as a counterweight to the cutting blade.

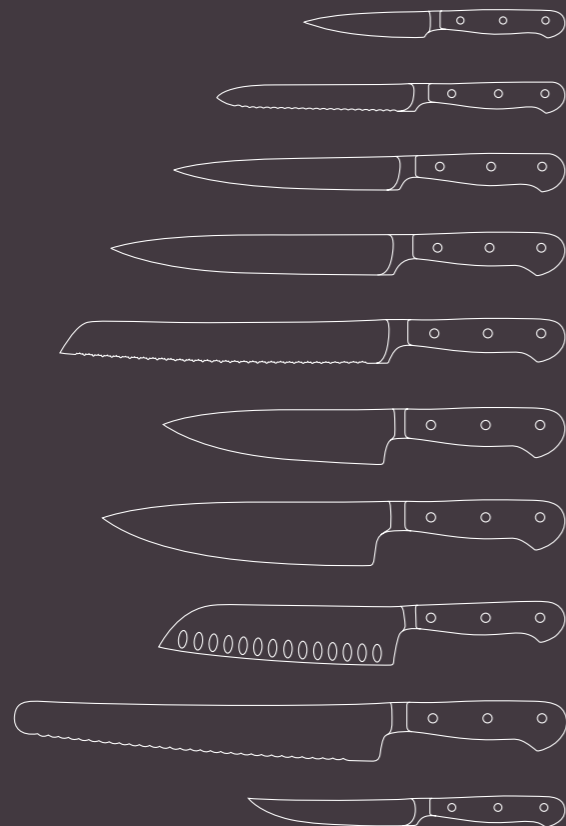

PARING KNIFE

WEIGHT: 51 G / BLADE LENGTH: 9 CM / BLADE WIDTH: 2 CM / TOTAL LENGTH: 18,8 CM

3765/09 / 4002293037653



SAUSAGE KNIFE

WEIGHT: 67 G / BLADE LENGTH: 14 CM / BLADE WIDTH: 2 CM / TOTAL LENGTH: 24,9 CM / WITH SERRATED EDGE

3710 / 4002293037103



COOK'S KNIFE

WEIGHT: 122 G / BLADE LENGTH: 16 CM / BLADE WIDTH: 4 CM / TOTAL LENGTH: 27,7 CM

3781/16 / 4002293437811



COOK'S KNIFE

WEIGHT: 189 G / BLADE LENGTH: 20 CM / BLADE WIDTH: 4,7 CM / TOTAL LENGTH: 32,8 CM

3781/20 / 4002293637815



UTILITY KNIFE

WEIGHT: 103 G / BLADE LENGTH: 16 CM / BLADE WIDTH: 2,5 CM / TOTAL LENGTH: 28,3 CM

3723/16 / 4002293437231



CARVING KNIFE

WEIGHT: 145 G / BLADE LENGTH: 20 CM / BLADE WIDTH: 3,1 CM / TOTAL LENGTH: 33 CM

3723/20 / 4002293537238



BREAD KNIFE

WEIGHT: 180 G / BLADE LENGTH: 23 CM / BLADE WIDTH: 3,1 CM / TOTAL LENGTH: 35,7 CM / WITH PRECISION DOUBLE SERRATED EDGE

3752/23 / 4002293737522



SANTOKU

WEIGHT: 162 G / BLADE LENGTH: 17 CM / BLADE WIDTH: 4,59 CM / TOTAL LENGTH: 30,3 CM / WITH HOLLOW EDGE

3783/17 / 4002293437835



SUPER SLICER

WEIGHT: 200 G / BLADE LENGTH: 26 CM / BLADE WIDTH: 4,1 CM / TOTAL LENGTH: 38,5 CM / WITH WAVY EDGE

NEW

3732/26 / 4002293104416



STEAK KNIFE SET

9738 / 4002293097381

CONTENT

4 x STEAK KNIFE / 12 CM



KNIFE BLOCK

WEIGHT: 1,63 KG / MATERIAL: SMOKED OAK, OAK, MAPLE, THERMO BEECH WOOD / B 14 CM x W 24 CM x D 11 CM

7230 / 4002293723006



Knives not included.

Sustainable tools for environmentally aware trendsetters



Pruning knife

HOME-GROWN, FRESHLY PREPARED, HEALTHY FOOD.

Urban Farmer combines the natural beauty of rustic crafting tools with the high-tech precision of knives made with the latest materials and techniques. The blade is made from stainless steel with a high carbon content. Its long-lasting sharpness is ensured by a Rockwell hardness of 58 and the solid tang gives it very high edge stability.

Made from sustainably grown and thermo treated beech wood, the handle is extremely robust and water-resistant. Combined with the non-slip bolster, it provides a secure grip. All the knives are well-balanced, easy-to-use and efficient tools that are ideal for cutting vegetables and meat or, like the unique pruning knife, for picking vegetables, fruit or herbs straight from your own garden or window-box.



Urban Farmer Pruning knife

Blades cut with precision laser

Non-slip, black bolster for safe work

Smooth-to-touch handle made from smoked beech



Perfectly suited for harvesting herbs and vegetables

For use indoors and outdoors



HANDLE

The handle made from smoked beech rewards the user with a natural texture which is smooth to touch. Like all high-quality knives, this knife must be washed by hand.



NON-SLIP BOLSTER

Always maintain a firm hold of the knife – the non-slip bolster is made from a high-performance special synthetic material. This way it offers absolutely secure grip, even when working with wet hands.



MACHETE

Harvest large vegetables and entire lettuce heads, dig planting holes or tend to beets – the powerful machete is the ultimate tool in the garden, and with the combination of a serrated edge and smooth grind, it is also perfect for kitchen preparation e.g. cabbage or pumpkin.



PRUNING KNIFE

With its distinctive curvature at the tip, this unique blade shape is perfectly suited for reaping, preening and peeling fruit and smaller vegetables.



SERRATED EDGE

Knives with the robust serrated edge cut every tomato into fine slices – and the same goes for most kinds of vegetables, soft fruits with solid skin or also bread, rolls and cured sausage.

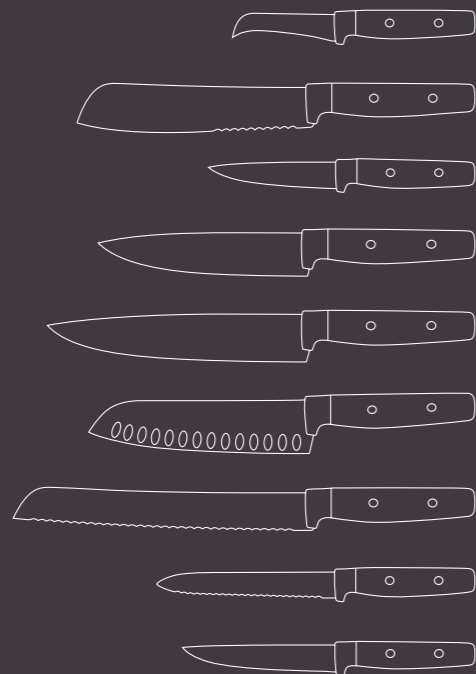

PRUNING KNIFE

WEIGHT: 63 G / BLADE LENGTH: 8 CM / BLADE WIDTH: 2,15 CM / TOTAL LENGTH: 18,8 CM

3400/08 / 4002293340012



PARING KNIFE

WEIGHT: 69 G / BLADE LENGTH: 10 CM / BLADE WIDTH: 2,15 CM / TOTAL LENGTH: 21 CM

3466/10 / 4002293346625



SERRATED UTILITY KNIFE

WEIGHT: 74 G / BLADE LENGTH: 14 CM / BLADE WIDTH: 2,15 CM / TOTAL LENGTH: 25 CM / WITH SERRATED EDGE

3410/14 / 4002293341019



COOK'S KNIFE

WEIGHT: 137 G / BLADE LENGTH: 16 CM / BLADE WIDTH: 3,55 CM / TOTAL LENGTH: 28,9 CM

3481/16 / 4002293348155



COOK'S KNIFE

WEIGHT: 163 G / BLADE LENGTH: 20 CM / BLADE WIDTH: 4 CM / TOTAL LENGTH: 32,9 CM

3481/20 / 4002293348179



BREAD KNIFE

WEIGHT: 180 G / BLADE LENGTH: 23 CM / BLADE WIDTH: 3,1 CM / TOTAL LENGTH: 35,8 CM / WITH SERRATED EDGE

3452/23 / 4002293345284



SANTOKU

WEIGHT: 162 G / BLADE LENGTH: 17 CM / BLADE WIDTH: 4,45 CM / TOTAL LENGTH: 29,8 CM / WITH HOLLOW EDGE

3483/17 / 4002293348353



MACHETE

WEIGHT: 153 G / BLADE LENGTH: 18 CM / BLADE WIDTH: 3,2 CM / TOTAL LENGTH: 30,8 CM / WITH SERRATED EDGE

3499/18 / 4002293349909



STEAK KNIFE SET

9401 / 4002293940106

CONTENT

4 x STEAK KNIFE / 12 CM



TOOL BASKET

WEIGHT: 2,67 KG / MATERIAL: BEECH WOOD, STAINLESS STEEL / W 37,5 CM x H 13,5 CM x D 17,5 CM

7410 / 4002293741000



Knives not included.

Elegance meets balance,
meets precision.



Santoku

DESIGN HYBRID WITH GERMAN AND JAPANESE ROOTS

EPICURE is an innovative cooking tool and combines the efficiency and lightness of Japanese knives with German quality and precision. In this way it represents a new type of knife for all cooking styles and sets pioneering standards in shape, function and performance.

Elegant geometry gives the EPICURE knives a balanced weight distribution which makes each model comfortable to hold. The organic design of the handle provides users of any hand size with the perfect grip – for agile work which is easy on the hands and wrists. At the same time, the newly designed bolster is the point of departure for a wider blade shape. This means that more pressure can be applied when cutting food and ensures optimum control for precise and safe cutting.





Epicure Santoku

Forged from one piece of stainless steel

Half bolster design for optimal weight balance

Full tang



Grind angle 20° / final buffing by hand

Handle made from sustainable natural fibre material



FULL TANG

As an extension of the blade, the tang gives the forged knife a reliable stability. As a counter-weight, it also ensures the blade is balanced.



INNOVATIVE HANDLE MATERIAL

Ergonomically shaped with perfect texture: The handle is made from sustainable natural fibre material, feels as pleasingly warm as wood and is as robust and hygienic as synthetic material.



HANDY HALF BOLSTER

The half bolster makes the leading grip position easier. Besides that, the blades are somewhat slimmer and glide more easily through the food item. The design also makes it possible to resharpen the blade continuously.



SAFER FULL BOLSTER

The full bolster reliably protects the fingers in everyday cooking and inspires all its users with an elegant alignment. The balance favours agile work.



SERRATED EDGE

With a robust serrated edge, the sausage knife cuts any tomato into fine slices – and the same goes for most types of vegetables, soft fruits with solid skin or even bread, rolls and cured sausage.



PRECISION DOUBLE SERRATED EDGE

The bread knife with the unique double serrated edge cuts hard crusts just as easily as soft bread or large fruits, such as pumpkin. The difference versus traditional serrated edges can be felt immediately.



PARING KNIFE

WEIGHT: 90 G / BLADE LENGTH: 9 CM / BLADE WIDTH: 2,35 CM / TOTAL LENGTH: 20,6 CM

3966/09 / 4002293396637



PARING KNIFE

WEIGHT: 94 G / BLADE LENGTH: 12 CM / BLADE WIDTH: 2,35 CM / TOTAL LENGTH: 23,6 CM

3966/12 / 4002293396675



STEAK KNIFE

WEIGHT: 98 G / BLADE LENGTH: 12 CM / BLADE WIDTH: 2,35 CM / TOTAL LENGTH: 23,9 CM

3968 / 4002293396835



SAUSAGE KNIFE

WEIGHT: 98 G / BLADE LENGTH: 14 CM / BLADE WIDTH: 2,35 CM / TOTAL LENGTH: 25,2 CM / WITH SERRATED EDGE

3911 / 4002293391120



COOK'S KNIFE

WEIGHT: 215 G / BLADE LENGTH: 16 CM / BLADE WIDTH: 4,7 CM / TOTAL LENGTH: 29,4 CM

3982/16 / 4002293398235



COOK'S KNIFE

WEIGHT: 245 G / BLADE LENGTH: 20 CM / BLADE WIDTH: 4,7 CM / TOTAL LENGTH: 33,4 CM

3982/20 / 4002293398259



COOK'S KNIFE

WEIGHT: 258 G / BLADE LENGTH: 24 CM / BLADE WIDTH: 4,7 CM / TOTAL LENGTH: 36,9 CM

3982/24 / 4002293398273



CARVING KNIFE

WEIGHT: 217 G / BLADE LENGTH: 23 CM / BLADE WIDTH: 4 CM / TOTAL LENGTH: 36,4 CM

3922/23 / 4002293392257



BREAD KNIFE

WEIGHT: 232 G / BLADE LENGTH: 23 CM / BLADE WIDTH: 4 CM / TOTAL LENGTH: 36,4 CM / WITH PRECISION DOUBLE SERRATED EDGE

3950/23 / 4002293395050



COOK'S KNIFE

WEIGHT: 198 G / BLADE LENGTH: 16 CM / BLADE WIDTH: 4,7 CM / TOTAL LENGTH: 28,8 CM / HALF BOLSTER

3981/16 / 4002293398143



COOK'S KNIFE

WEIGHT: 225 G / BLADE LENGTH: 20 CM / BLADE WIDTH: 4,7 CM / TOTAL LENGTH: 32,8 CM / HALF BOLSTER

3981/20 / 4002293398167



SANTOKU

WEIGHT: 204 G / BLADE LENGTH: 17 CM / BLADE WIDTH: 5,68 CM / TOTAL LENGTH: 29,7 CM / HALF BOLSTER / WITH HOLLOW EDGE

3983 / 4002293398327



MAGNETIC BLOCK

WEIGHT: 4,45 KG / MATERIAL: THERMO BEECH WOOD, STAINLESS STEEL / WOODEN PART: W 36 x H 24 x D 4 CM / KNIFE BLOCK WITH BASE: W 36,5 x H 28 x D 15,5 CM

7231 / 4002293723105



Knives not included.

Forged luxury. Each knife a unique specimen.



Cook's knife

SHARP BLADES AND PREMIUM-QUALITY WOOD

With their special features, the knives in the IKON series are a feast for the senses. The exceptional handles made from exquisite African blackwood are characterised by their individual texture, making each knife a veritable eye-catcher. The luxurious wood is water-resistant and its hygienic qualities make it particularly well suited for use in the kitchen.

At the same time, with their natural, comfortably warm feel and ergonomic shape, the handles are especially delightful to hold. The unique geometry with double bolster ensures optimum balance and guarantees effortless work, even when used for longer periods.

The blades are forged from high-quality chromium molybdenum vanadium steel and are characterised by a high level of robustness and durability. The final edge-work carried out by hand by the experienced WÜSTHOF specialists ensures extreme sharpness – and quick and easy cutting.



Ikon Cook's knife

Forged from one piece of stainless steel

Balanced using double bolster geometry

Full tang

Grind angle 29°/ final buffing by hand

Handle made from sustainably grown African blackwood



DOUBLE BOLSTER GEOMETRY

Balance and ergonomics – the special geometry with double bolster ensures balanced handling. The knife therefore sits well in the hand and guarantees effortless cutting.



HALF BOLSTER

The knife weighs less thanks to its slim bolster design. This allows energy-saving work. In addition, the design allows the entire blade to be used and resharpened.



PEELING KNIFE

The handy knife with a short, curved cutting edge is especially well suited for peeling and cleaning round fruits and vegetables. Valuable vitamins remain intact thanks to the precision blade reducing food waste.



HANDLE

The handles made from African blackwood are permanently riveted and assembled seamlessly. The water-resistant wood is exceptionally hygienic and originates from controlled cultivation.



HOLLOW EDGE

Small air pockets are created on the depressions of the blade through the hollow edge. The positive effect of this is that thin or soft food items can be removed from the blade more easily during use.



PRECISION DOUBLE SERRATED EDGE

The bread knife with the unique double serrated edge cuts hard crusts just as easily as soft bread or large fruits, like pumpkin. The difference versus traditional serrated edges can be felt immediately.

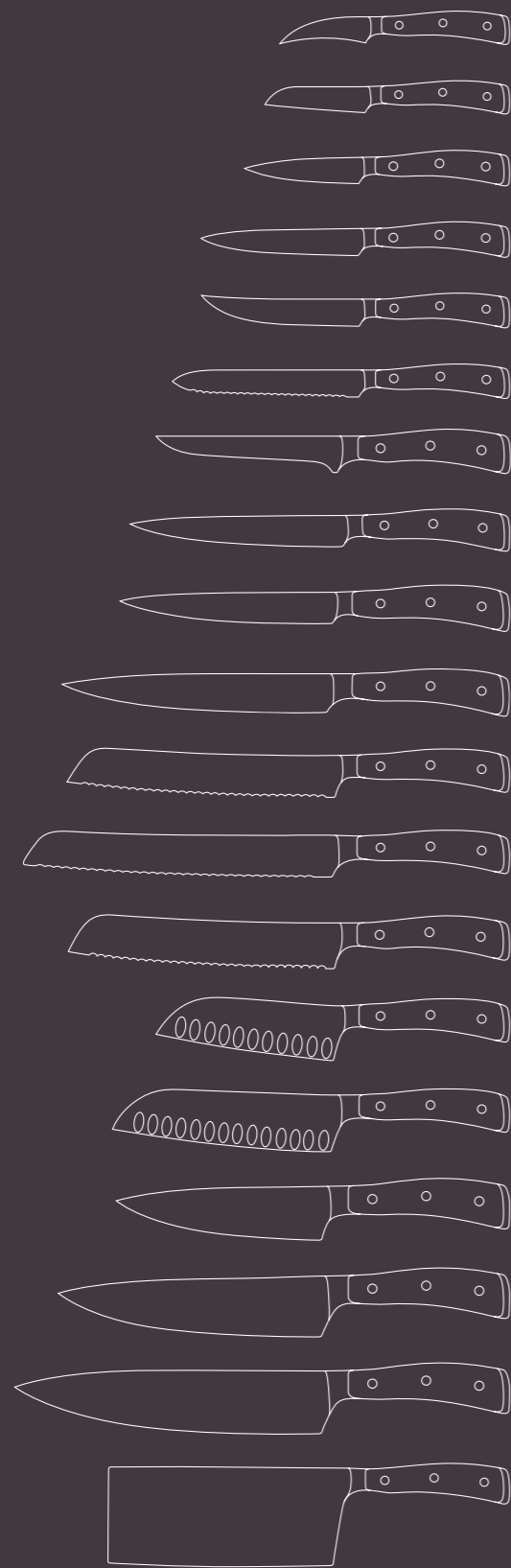

PEELING KNIFE

WEIGHT: 69 G / BLADE LENGTH: 7 CM / BLADE WIDTH: 2 CM / TOTAL LENGTH: 17,9 CM

4920 / 4002293492001



PARING KNIFE

WEIGHT: 71 G / BLADE LENGTH: 8 CM / BLADE WIDTH: 2 CM / TOTAL LENGTH: 18,9 CM

4984 / 4002293498409



PARING KNIFE

WEIGHT: 73 G / BLADE LENGTH: 9 CM / BLADE WIDTH: 2 CM / TOTAL LENGTH: 20,5 CM

4986/09 / 4002293498614



UTILITY KNIFE

WEIGHT: 77 G / BLADE LENGTH: 12 CM / BLADE WIDTH: 2 CM / TOTAL LENGTH: 22 CM

4986/12 / 4002293498638



STEAK KNIFE

WEIGHT: 78 G / BLADE LENGTH: 12 CM / BLADE WIDTH: 2 CM / TOTAL LENGTH: 22,2 CM

4988 / 4002293498805



SAUSAGE KNIFE

WEIGHT: 80 G / BLADE LENGTH: 14 CM / BLADE WIDTH: 2 CM / TOTAL LENGTH: 25 CM / WITH SERRATED EDGE

4926 / 4002293492605



BONING KNIFE

WEIGHT: 147 G / BLADE LENGTH: 14 CM / BLADE WIDTH: 2,8 CM / TOTAL LENGTH: 27 CM

4958 / 4002293495804



FILLET KNIFE

WEIGHT: 119 G / BLADE LENGTH: 16 CM / BLADE WIDTH: 2,5 CM / TOTAL LENGTH: 28,6 CM / FLEXIBEL

4956 / 4002293495613



UTILITY KNIFE

WEIGHT: 126 G / BLADE LENGTH: 16 CM / BLADE WIDTH: 2,5 CM / TOTAL LENGTH: 28,6 CM

4906/16 / 4002293490625



CARVING KNIFE

WEIGHT: 168 G / BLADE LENGTH: 20 CM / BLADE WIDTH: 3,1 CM / TOTAL LENGTH: 33,4 CM

4906/20 / 4002293490649



BREAD KNIFE

WEIGHT: 150 G / BLADE LENGTH: 20 CM / BLADE WIDTH: 3,1 CM / TOTAL LENGTH: 32,4 CM / WITH SERRATED EDGE

4966/20 / 4002293496610



BREAD KNIFE

WEIGHT: 196 G / BLADE LENGTH: 23 CM / BLADE WIDTH: 3,1 CM / TOTAL LENGTH: 35,9 CM / WITH SERRATED EDGE

4966/23 / 4002293496627



BREAD KNIFE

WEIGHT: 201 G / BLADE LENGTH: 23 CM / BLADE WIDTH: 3,1 CM / TOTAL LENGTH: 35,6 CM / WITH PRECISION DOUBLE SERRATED EDGE

4963/23 / 4002293496351



SANTOKU

WEIGHT: 140 G / BLADE LENGTH: 14 CM / BLADE WIDTH: 4,12 CM / TOTAL LENGTH: 25,6 CM / WITH HOLLOW EDGE

4972 / 4002293497204



SANTOKU

WEIGHT: 201 G / BLADE LENGTH: 17 CM / BLADE WIDTH: 4,57 CM / TOTAL LENGTH: 30,7 CM / WITH HOLLOW EDGE

4976 / 4002293497600



COOK'S KNIFE

WEIGHT: 181 G / BLADE LENGTH: 16 CM / BLADE WIDTH: 4 CM / TOTAL LENGTH: 29 CM

4996/16 / 4002293499628



COOK'S KNIFE

WEIGHT: 270 G / BLADE LENGTH: 20 CM / BLADE WIDTH: 4,7 CM / TOTAL LENGTH: 34,1 CM

4996/20 / 4002293499642



COOK'S KNIFE

WEIGHT: 279 G / BLADE LENGTH: 23 CM / BLADE WIDTH: 4,7 CM / TOTAL LENGTH: 36,7 CM

4996/23 / 4002293499659



CHINESE CHEF'S KNIFE

WEIGHT: 350 G / BLADE LENGTH: 18 CM / BLADE WIDTH: 7,75 CM / TOTAL LENGTH: 32,4 CM

4973/18 / 4002293497334



KNIFE BLOCK

WEIGHT: 2,91 KG / MATERIAL: THERMO BEECH WOOD / B 15 CM x H 28,7 CM x T 15 CM

7262 / 4002293726205



Knives not included.

Extreme precision with perfect ergonomics

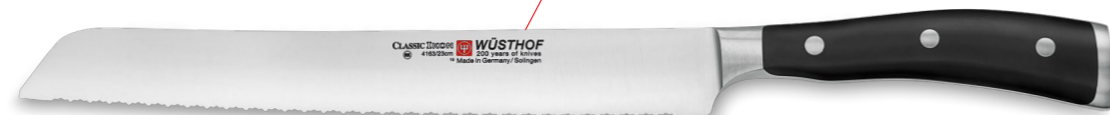

Bread knife

BLACK AND ELEGANT. AGILE AND ROBUST.

The CLASSIC IKON series combines perfect ergonomics, excellent balance and ultimately sharp blades with a timeless design. Before they are sharpened, each blade is measured using lasers by means of the PEtec procedure patented by WÜSTHOF. This gives them the optimum cutting angle for the greatest possible initial sharpness.

Thanks to their special shaping, the knives are well-balanced and their ergonomic handles make them comfortable to hold. The handle shells are made from special synthetic material and are durably riveted, making them completely hygienic and easy to use. They are recommended for everyday effortless kitchen use by home cooks and professional chefs alike.

What's more: CLASSIC IKON is the tool used by the German National Culinary Team.





Classic Ikon Bread knife

Forged from one piece of stainless steel

Half bolster design for optimal weight balance

Double bolster with high quality logo lasering



Precision double serrated edge / stays sharper for longer, less effort when cutting

Triple riveted

Full tang



DOUBLE BOLSTER GEOMETRY

Balance and ergonomics – the special geometry with double bolster for balanced handling. The knife sits comfortably in the hand and guarantees effortless cutting.



HALF BOLSTER

The knife weighs less thanks to the slim bolster design. This allows energy-saving work. In addition, the design allows the whole blade to be used and resharpened.



WAVY EDGE

The wavy edge formed from the inside produces a clean cut and is well-suited for large fruits, vegetables or roasts. With a broad, long blade it is also perfectly suited as a bread and cake knife.



PRECISION DOUBLE SERRATED EDGE

The bread knife with the unique double serrated edge cuts hard crusts just as easily as soft bread or large fruits, like pumpkin. The difference versus traditional serrated edges can be felt immediately.



PEELING KNIFE

The handy knife with the short, curved cutting edge is especially well suited for peeling and cleaning round fruits and vegetables. Valuable vitamins remain intact thanks to the precision blade minimising food waste.



NAKIRI

This knife is equipped with an exceptionally slim, Asian style blade and is extremely sharp with a grinding angle of 20°. The flutes ensure that thin or soft food items can be removed from the blade more easily during use.

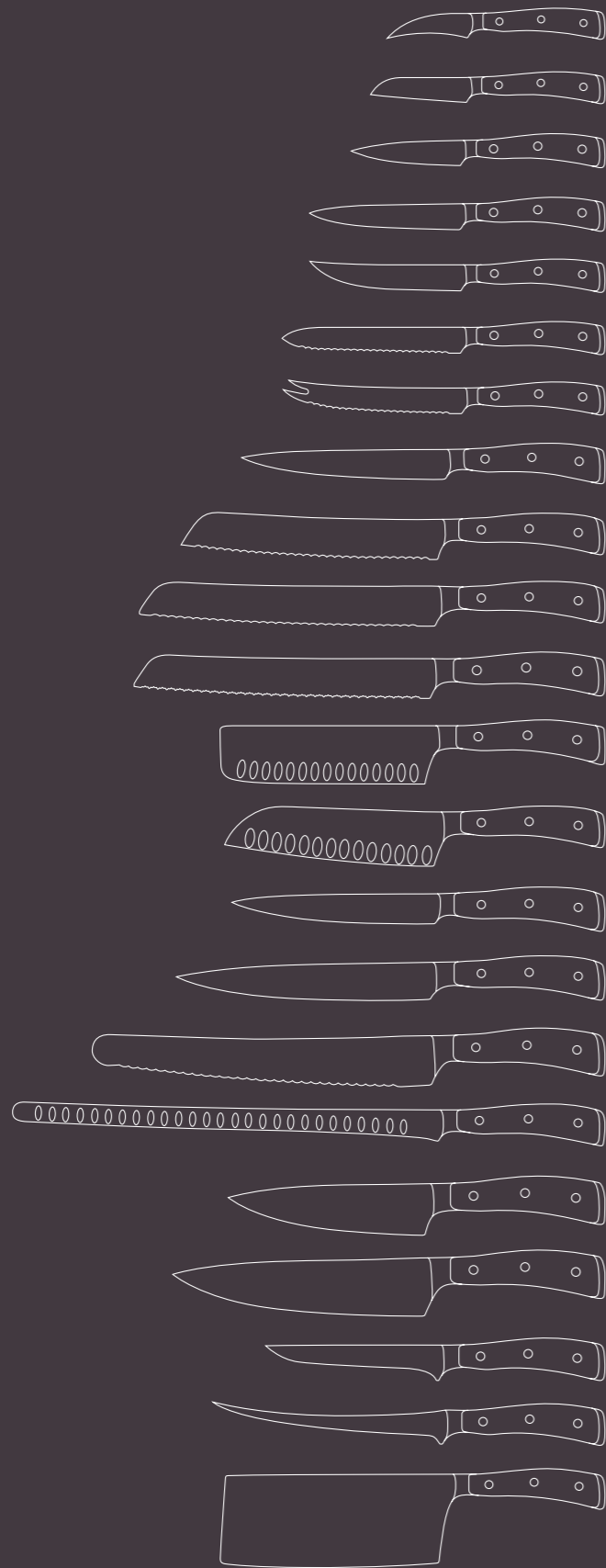

PEELING KNIFE

WEIGHT: 65 G / BLADE LENGTH: 7 CM / BLADE WIDTH: 2 CM / TOTAL LENGTH: 17,9 CM

4020 / 4002293402000



PARING KNIFE

WEIGHT: 76 G / BLADE LENGTH: 8 CM / BLADE WIDTH: 2 CM / TOTAL LENGTH: 18,9 CM

4006 / 4002293400600



PARING KNIFE

WEIGHT: 76 G / BLADE LENGTH: 9 CM / BLADE WIDTH: 2 CM / TOTAL LENGTH: 20,5 CM

4086/09 / 4002293408613



UTILITY KNIFE

WEIGHT: 78 G / BLADE LENGTH: 12 CM / BLADE WIDTH: 2 CM / TOTAL LENGTH: 22,9 CM

4086/12 / 4002293408637



STEAK KNIFE

WEIGHT: 78 G / BLADE LENGTH: 12 CM / BLADE WIDTH: 2 CM / TOTAL LENGTH: 22,9 CM

4096 / 4002293409603



SAUSAGE KNIFE

WEIGHT: 87 G / BLADE LENGTH: 14 CM / BLADE WIDTH: 2 CM / TOTAL LENGTH: 25 CM / WITH SERRATED EDGE

4126 / 4002293412603



TOMATO KNIFE

WEIGHT: 78 G / BLADE LENGTH: 14 CM / BLADE WIDTH: 2 CM / TOTAL LENGTH: 25 CM / WITH SERRATED EDGE

4136 / 4002293413600



BONING KNIFE

WEIGHT: 164 G / BLADE LENGTH: 14 CM / BLADE WIDTH: 2,8 CM / TOTAL LENGTH: 27 CM

4616 / 4002293461601



FILLET KNIFE

WEIGHT: 126 G / BLADE LENGTH: 16 CM / BLADE WIDTH: 2,5 CM / TOTAL LENGTH: 28,6 CM / FLEXIBLE

4556 / 4002293455617



FILLET KNIFE

WEIGHT: 157 G / BLADE LENGTH: 18 CM / BLADE WIDTH: 2,33 CM / TOTAL LENGTH: 31,3 CM

4626 / 4002293462608



BREAD KNIFE

WEIGHT: 154 G / BLADE LENGTH: 20 CM / BLADE WIDTH: 3,1 CM / TOTAL LENGTH: 32,4 CM / WITH SERRATED EDGE

4166/20 / 4002293416618



BREAD KNIFE

WEIGHT: 204 G / BLADE LENGTH: 23 CM / BLADE WIDTH: 3,1 CM / TOTAL LENGTH: 36 CM / WITH SERRATED EDGE

4166/23 / 4002293416625



BREAD KNIFE

WEIGHT: 201 G / BLADE LENGTH: 23 CM / BLADE WIDTH: 3,1 CM / TOTAL LENGTH: 36 CM / WITH PRECISION DOUBLE SERRATED EDGE

4163/23 / 4002293416359



SUPER SLICER

WEIGHT: 266 G / BLADE LENGTH: 26 CM / BLADE WIDTH: 4,24 CM / TOTAL LENGTH: 39,6 CM / WITH WAVY EDGE

4516 / 4002293451602



SALMON SLICER

WEIGHT: 143 G / BLADE LENGTH: 32 CM / BLADE WIDTH: 2,33 CM / TOTAL LENGTH: 44,2 CM / FLEXIBLE / WITH HOLLOW EDGE

4546 / 4002293454603



COOK'S KNIFE

WEIGHT: 183 G / BLADE LENGTH: 16 CM / BLADE WIDTH: 4 CM / TOTAL LENGTH: 29 CM

4596/16 / 4002293459622



COOK'S KNIFE

WEIGHT: 189 G / BLADE LENGTH: 18 CM / BLADE WIDTH: 4 CM / TOTAL LENGTH: 30,5 CM

4596/18 / 4002293459639



COOK'S KNIFE

WEIGHT: 271 G / BLADE LENGTH: 20 CM / BLADE WIDTH: 4,7 CM / TOTAL LENGTH: 34,1 CM

4596/20 / 4002293459646



COOK'S KNIFE

WEIGHT: 290 G / BLADE LENGTH: 23 CM / BLADE WIDTH: 4,7 CM / TOTAL LENGTH: 36,7 CM

4596/23 / 4002293459653



COOK'S KNIFE

WEIGHT: 302 G / BLADE LENGTH: 26 CM / BLADE WIDTH: 4,7 CM / TOTAL LENGTH: 39,4 CM

4596/26 / 4002293459660



UTILITY KNIFE

WEIGHT: 131 G / BLADE LENGTH: 16 CM / BLADE WIDTH: 2,5 CM / TOTAL LENGTH: 28,6 CM

4506/16 / 4002293450629



CARVING KNIFE

WEIGHT: 180 G / BLADE LENGTH: 20 CM / BLADE WIDTH: 3,1 CM / TOTAL LENGTH: 32,7 CM

4506/20 / 4002293450643



CARVING KNIFE

WEIGHT: 182 G / BLADE LENGTH: 23 CM / BLADE WIDTH: 3,1 CM / TOTAL LENGTH: 35,7 CM

4506/23 / 4002293450650



SANTOKU

WEIGHT: 149 G / BLADE LENGTH: 14 CM / BLADE WIDTH: 4,1 CM / TOTAL LENGTH: 25,6 CM / WITH HOLLOW EDGE

4172 / 4002293417202



SANTOKU

WEIGHT: 203 G / BLADE LENGTH: 17 CM / BLADE WIDTH: 4,6 CM / TOTAL LENGTH: 30,7 CM / WITH HOLLOW EDGE

4176 / 4002293417608



NAKIRI

WEIGHT: 204 G / BLADE LENGTH: 17 CM / BLADE WIDTH: 4,69 CM / TOTAL LENGTH: 29,7 CM / WITH HOLLOW EDGE

4187/17 / 4002293418742



CHINESISCHES COOK'S KNIFE

WEIGHT: 350 G / BLADE LENGTH: 18 CM / BLADE WIDTH: 7,75 CM / TOTAL LENGTH: 32,4 CM

4673/18 / 4002293467337



KNIFE BLOCK

WEIGHT: 2,8 KG / MATERIAL: ASH WOOD, BLACK / W 28,4 CM x H 24,3 CM x D 14,6 CM

7253 / 4002293725307



Knives not included.

The bright alternative for modern kitchens

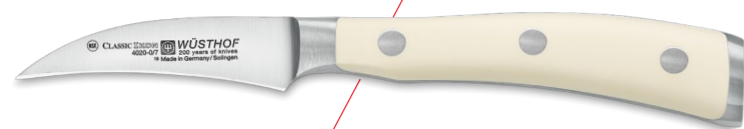

Peeling knife

ELEGANT DESIGN. OUTSTANDING FUNCTIONALITY.

With their cream-coloured handles, the knives in the CLASSIC IKON series are not only a specialty within the knife market, but also a real eye-catcher in any kitchen. The handle shells made from special synthetic material are, like the black CLASSIC IKON, firmly riveted, seamlessly assembled and so meet the highest hygiene standards.

Thanks to the innovative bolster geometry as well as the ergonomic, edgeless design of the handle, the knife sits perfectly balanced in your hand and is effortless to use. The blades are extremely sharp and will remain so for a very long time. The special workmanship makes cutting, chopping and portioning a delight.





Classic Ikon Peeling knife

Forged from one piece of stainless steel

Half bolster for optimal handling

Double bolster with high quality logo lasering



Grinding angle 30° / final buffing by hand

Handle shells made from special synthetic material

Full tang

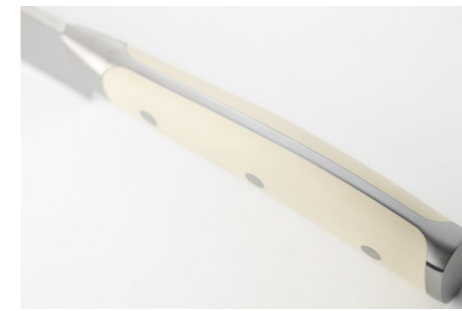

DOUBLE BOLSTER GEOMETRY

Balance and ergonomics – the special geometry with double bolster ensures balanced handling. The knife sits comfortably in the hand and guarantees effortless cutting.



PEELING KNIFE

The handy knife with a short, curved cutting edge is especially well-suited for peeling and cleaning round fruit and vegetables. Valuable vitamins remain intact thanks to the precision blade reducing food waste.



HALF BOLSTER

The knife's weight is reduced by the slim bolster design. This allows for energy-saving work. In addition, the design allows the entire blade to be used and resharpened.



HOLLOW EDGE

Small air pockets are created at the depressions of the blade through the hollow edge. The positive effect of this is that thin or soft food items do not stick to the blade.



HANDLE HEEL WITH LOGO

The ergonomic handle not only ensures perfect grip; it is also riveted with an elegantly lasered trident logo.



PRECISION DOUBLE SERRATED EDGE

The bread knife with the unique double serrated edge cuts hard crusts just as effortlessly as soft bread or large fruits, such as pumpkin. The difference versus traditional serrated edges can be felt immediately.

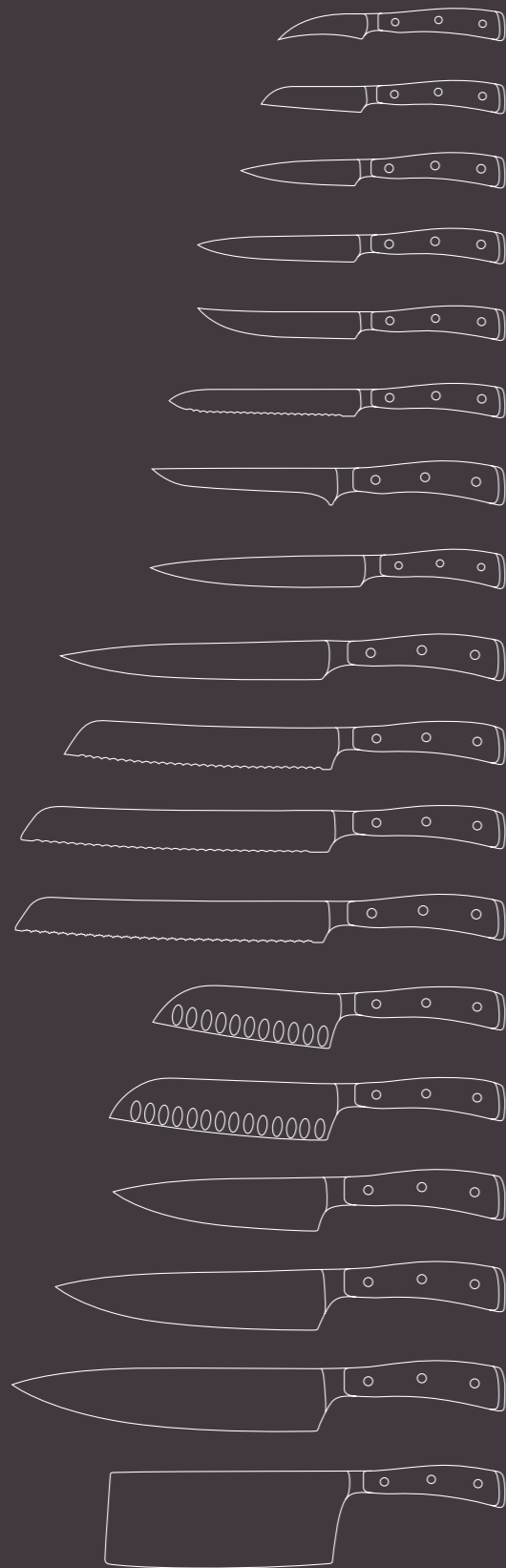

PEELING KNIFE

WEIGHT: 65 G / BLADE LENGTH: 7 CM / BLADE WIDTH: 2 CM / TOTAL LENGTH: 17,9 CM

4020-0 / 4002293202006



PARING KNIFE

WEIGHT: 76 G / BLADE LENGTH: 8 CM / BLADE WIDTH: 2 CM / TOTAL LENGTH: 18,9 CM

4006-0 / 4002293200606



PARING KNIFE

WEIGHT: 76 G / BLADE LENGTH: 9 CM / BLADE WIDTH: 2 CM / TOTAL LENGTH: 20,5 CM

4086-0/09 / 4002293208619



UTILITY KNIFE

WEIGHT: 81 G / BLADE LENGTH: 12 CM / BLADE WIDTH: 2 CM / TOTAL LENGTH: 22,9 CM

4086-0/12 / 4002293208626



STEAK KNIFE

WEIGHT: 78 G / BLADE LENGTH: 12 CM / BLADE WIDTH: 2 CM / TOTAL LENGTH: 22,9 CM

4096-0 / 4002293209609



SAUSAGE KNIFE

WEIGHT: 87 G / BLADE LENGTH: 14 CM / BLADE WIDTH: 2 CM / TOTAL LENGTH: 25 CM / WITH SERRATED EDGE

4126-0 / 4002293212609



BONING KNIFE

WEIGHT: 156 G / BLADE LENGTH: 14 CM / BLADE WIDTH: 2,8 CM / TOTAL LENGTH: 27 CM

4616-0 / 4002293261607



FILLET KNIFE

WEIGHT: 123 G / BLADE LENGTH: 16 CM / BLADE WIDTH: 2,5 CM / TOTAL LENGTH: 28,6 CM / FLEXIBLE

4556-0 / 4002293255606



UTILITY KNIFE

WEIGHT: 133 G / BLADE LENGTH: 16 CM / BLADE WIDTH: 2,5 CM / TOTAL LENGTH: 28,6 CM

4506-0/16 / 4002293250625



CARVING KNIFE

WEIGHT: 178 G / BLADE LENGTH: 20 CM / BLADE WIDTH: 3,1 CM / TOTAL LENGTH: 33,4 CM

4506-0/20 / 4002293250649



BREAD KNIFE

WEIGHT: 154 G / BLADE LENGTH: 20 CM / BLADE WIDTH: 3,1 CM / TOTAL LENGTH: 32,1 CM / WITH SERRATED EDGE

4166-0/20 / 4002293216645



BREAD KNIFE

WEIGHT: 204 G / BLADE LENGTH: 23 CM / BLADE WIDTH: 3,1 CM / TOTAL LENGTH: 36 CM / WITH SERRATED EDGE

4166-0/23 / 4002293246659



BREAD KNIFE

WEIGHT: 201 G / BLADE LENGTH: 23 CM / BLADE WIDTH: 3,1 CM / TOTAL LENGTH: 36 CM / WITH PRECISION DOUBLE SERRATED EDGE

4163-0/23 / 4002293216355



SANTOKU

WEIGHT: 149 G / BLADE LENGTH: 14 CM / BLADE WIDTH: 4,1 CM / TOTAL LENGTH: 25,6 CM / WITH HOLLOW EDGE

4172-0 / 4002293217208



SANTOKU

WEIGHT: 203 G / BLADE LENGTH: 17 CM / BLADE WIDTH: 4,6 CM / TOTAL LENGTH: 30,7 CM / WITH HOLLOW EDGE

4176-0 / 4002293217604



COOK'S KNIFE

WEIGHT: 182 G / BLADE LENGTH: 16 CM / BLADE WIDTH: 4 CM / TOTAL LENGTH: 29 CM

4596-0/16 / 4002293259628



COOK'S KNIFE

WEIGHT: 273 G / BLADE LENGTH: 20 CM / BLADE WIDTH: 4,7 CM / TOTAL LENGTH: 34,1 CM

4596-0/20 / 4002293259642



COOK'S KNIFE

WEIGHT: 292 G / BLADE LENGTH: 23 CM / BLADE WIDTH: 4,7 CM / TOTAL LENGTH: 36,7 CM

4596-0/23 / 4002293259659



CHINESE CHEF'S KNIFE

WEIGHT: 350 G / BLADE LENGTH: 18 CM / BLADE WIDTH: 7,75 CM / TOTAL LENGTH: 32,4 CM

4673-0/18 / 4002293267333



KNIFE BLOCK

WEIGHT: 2,8 KG / MATERIAL: ASH WOOD, CRÈME / W 28,4 CM x H 24,3 CM x D 14,6 CM

7254 / 4002293725406



Knives not included.

Number one for forged kitchen knives



Cook's knife

LARGEST SELECTION. CONSISTENT QUALITY.

With a selection of blades from 7 to 36 cm in length and a range of ca. 70 blade shapes, CLASSIC offers the largest variety of models in the world. The series stands out because of its clear design and ease of use and so is the right tool for every home cook and professional.

Quality comes first. With 55 sophisticated manufacturing stages and more than 20 uncompromising quality checks, each CLASSIC knife is perfectly manufactured. The blades are forged from one piece of high alloy chrome molybdenum vanadium steel, and are exceptionally sharp, robust and long-lasting thanks to the laser-supported sharpening process PEtec.





Classic Cook's knife

Forged from one piece of stainless steel

Safe work thanks to full bolster

Triple riveted



Grind angle 29° / final buffing by hand

Full tang

Hand guard



HAND GUARD

The knife handle sits in the hand comfortably and is curved slightly downwards at the heel to avoid slipping. The robust handle shells are secured with stainless steel rivets and manufactured seamlessly.



FULL BOLSTER

The full bolster reliably protects the fingers in everyday cooking and the balance makes agile and precision work easier.



FULL TANG

As an extension of the blade, the tang gives the knife reliable stability. In addition, as a counter-weight it ensures the blade is balanced.



HOLLOW EDGE

Small air pockets are produced by the hollow edge on the depressions of the blade. The positive effect of this is that thin or soft food items are more easily removed from the blade during use.



PRECISION DOUBLE SERRATED EDGE

The bread knife with the unique double serrated edge cuts hard crusts just as easily as soft bread or large fruits, such as pumpkin. The difference versus traditional serrated edges can be felt immediately.



BUTCHER KNIFE

The distinctive new knife is perfect for portioning meat and also cuts large fruits and vegetables effortlessly. The special design makes it into an extraordinary work of art, forged from steel.

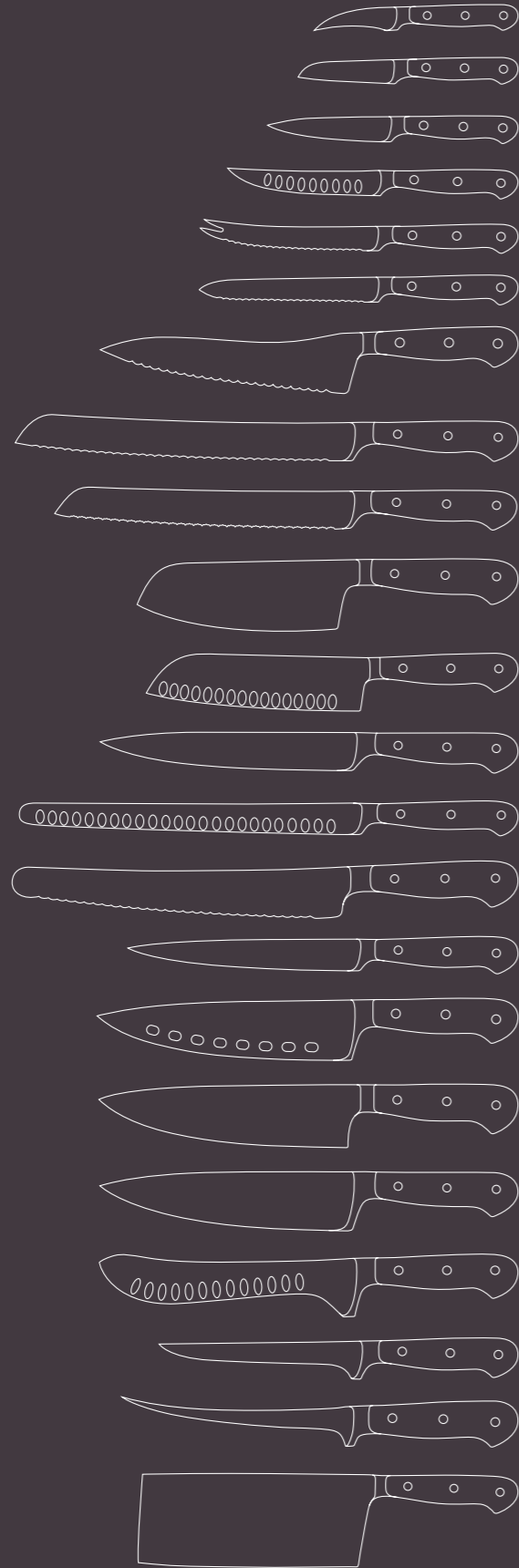

PEELING KNIFE

WEIGHT: 59 G / BLADE LENGTH: 7 CM / BLADE WIDTH: 2 CM / TOTAL LENGTH: 17,1 CM

4062 / 4002293406206



TRIMMING KNIFE

WEIGHT: 58 G / BLADE LENGTH: 7 CM / BLADE WIDTH: 2 CM / TOTAL LENGTH: 17,1 CM

4002 / 4002293400204



PARING KNIFE

WEIGHT: 61 G / BLADE LENGTH: 8 CM / BLADE WIDTH: 2 CM / TOTAL LENGTH: 18,1 CM

4000 / 4002293400006



PARING KNIFE

WEIGHT: 71 G / BLADE LENGTH: 9 CM / BLADE WIDTH: 2 CM / TOTAL LENGTH: 19,1 CM

4066/09 / 4002293406619



PARING KNIFE

WEIGHT: 73 G / BLADE LENGTH: 10 CM / BLADE WIDTH: 2 CM / TOTAL LENGTH: 20,1 CM

4066/10 / 4002293406626



UTILITY KNIFE

WEIGHT: 71 G / BLADE LENGTH: 12 CM / BLADE WIDTH: 2 CM / TOTAL LENGTH: 22,9 CM

4066/12 / 4002293406633



STEAK KNIFE

WEIGHT: 84 G / BLADE LENGTH: 12 CM / BLADE WIDTH: 2 CM / TOTAL LENGTH: 22,9 CM

4068 / 4002293406800



SAUSAGE KNIFE

WEIGHT: 80 G / BLADE LENGTH: 14 CM / BLADE WIDTH: 2 CM / TOTAL LENGTH: 24,9 CM / WITH SERRATED EDGE

4110 / 4002293411002



TOMATO KNIFE

WEIGHT: 76 G / BLADE LENGTH: 14 CM / BLADE WIDTH: 2 CM / TOTAL LENGTH: 24,9 CM / WITH SERRATED EDGE

4109 / 4002293410906



BREAD KNIFE

WEIGHT: 132 G / BLADE LENGTH: 20 CM / BLADE WIDTH: 2,5 CM / TOTAL LENGTH: 32,1 CM / WITH SERRATED EDGE

4149 / 4002293414904



BREAD KNIFE

WEIGHT: 190 G / BLADE LENGTH: 23 CM / BLADE WIDTH: 3,1 CM / TOTAL LENGTH: 35,7 CM / WITH SERRATED EDGE

4150 / 4002293415000



BREAD KNIFE

WEIGHT: 197 G / BLADE LENGTH: 26 CM / BLADE WIDTH: 3,1 CM / TOTAL LENGTH: 38,7 CM / WITH SERRATED EDGE

4151 / 4002293415109



BREAD KNIFE

WEIGHT: 185 G / BLADE LENGTH: 23 CM / BLADE WIDTH: 3,1 CM / TOTAL LENGTH: 35,7 CM / WITH PRECISION DOUBLE SERRATED EDGE

4152/23 / 4002293415208



BREAD KNIFE

WEIGHT: 176 G / BLADE LENGTH: 20 CM / BLADE WIDTH: 4,85 CM / TOTAL LENGTH: 33 CM / WITH WAVY EDGE

4128 / 4002293412801



COOK'S KNIFE

WEIGHT: 119 G / BLADE LENGTH: 12 CM / BLADE WIDTH: 3,6 CM / TOTAL LENGTH: 23 CM

4582/12 / 4002293458205



COOK'S KNIFE

WEIGHT: 129 G / BLADE LENGTH: 14 CM / BLADE WIDTH: 3,6 CM / TOTAL LENGTH: 26,2 CM

4582/14 / 4002293458212



COOK'S KNIFE

WEIGHT: 174 G / BLADE LENGTH: 16 CM / BLADE WIDTH: 4 CM / TOTAL LENGTH: 28,5 CM

4582/16 / 4002293458229



COOK'S KNIFE

WEIGHT: 189 G / BLADE LENGTH: 18 CM / BLADE WIDTH: 4 CM / TOTAL LENGTH: 30,5 CM

4582/18 / 4002293458236



COOK'S KNIFE

WEIGHT: 268 G / BLADE LENGTH: 20 CM / BLADE WIDTH: 4,7 CM / TOTAL LENGTH: 33,7 CM

4582/20 / 4002293458243



COOK'S KNIFE

WEIGHT: 282 G / BLADE LENGTH: 23 CM / BLADE WIDTH: 4,7 CM / TOTAL LENGTH: 36,6 CM

4582/23 / 4002293458250



COOK'S KNIFE

WEIGHT: 290 G / BLADE LENGTH: 26 CM / BLADE WIDTH: 4,7 CM / TOTAL LENGTH: 39,5 CM

4582/26 / 4002293458267



COOK'S KNIFE

WEIGHT: 282 G / BLADE LENGTH: 20 CM / BLADE WIDTH: 5,6 CM / TOTAL LENGTH: 33,1 CM / EXTRA WIDE

4584/20 / 4002293458410



COOK'S KNIFE

WEIGHT: 313 G / BLADE LENGTH: 26 CM / BLADE WIDTH: 5,6 CM / TOTAL LENGTH: 39,2 CM / EXTRA WIDE

4584/26 / 4002293458427



COOK'S KNIFE

WEIGHT: 264 G / BLADE LENGTH: 20 CM / BLADE WIDTH: 4,7 CM / TOTAL LENGTH: 33,6 CM / WITH HOLLOW EDGE

4572/20 / 4002293457246



BONING KNIFE

WEIGHT: 99 G / BLADE LENGTH: 10 CM / BLADE WIDTH: 2,5 CM / TOTAL LENGTH: 22,2 CM

4601 / 4002293460109



BONING KNIFE

WEIGHT: 141 G / BLADE LENGTH: 14 CM / BLADE WIDTH: 3,1 CM / TOTAL LENGTH: 26,9 CM

4602 / 4002293460208



BONING KNIFE

WEIGHT: 145 G / BLADE LENGTH: 16 CM / BLADE WIDTH: 3,1 CM / TOTAL LENGTH: 28,9 CM / FLEXIBLE

4603 / 4002293460307



CURVED UTILITY KNIFE

WEIGHT: 124 G / BLADE LENGTH: 16 CM / BLADE WIDTH: 3 CM / TOTAL LENGTH: 28 CM

4610/16 / 4002293461014



FISH FILLET KNIFE

WEIGHT: 74 G / BLADE LENGTH: 16 CM / BLADE WIDTH: 2 CM / TOTAL LENGTH: 26,9 CM / FLEXIBLE

4518/16 / 4002293451817



FISH FILLET KNIFE

WEIGHT: 81 G / BLADE LENGTH: 20 CM / BLADE WIDTH: 2 CM / TOTAL LENGTH: 30,9 CM / FLEXIBLE

4518/20 / 4002293451824



FILLET KNIFE

WEIGHT: 105 G / BLADE LENGTH: 16 CM / BLADE WIDTH: 2,5 CM / TOTAL LENGTH: 28,2 CM / FLEXIBLE

4550/16 / 4002293455013



FILLET KNIFE

WEIGHT: 110 G / BLADE LENGTH: 18 CM / BLADE WIDTH: 2,5 CM / TOTAL LENGTH: 30,1 CM / FLEXIBLE

4550/18 / 4002293455020



FILLET KNIFE

WEIGHT: 141 G / BLADE LENGTH: 18 CM / BLADE WIDTH: 3,1 CM / TOTAL LENGTH: 30,7 CM

4622 / 4002293462202



UTILITY KNIFE

WEIGHT: 111 G / BLADE LENGTH: 14 CM / BLADE WIDTH: 2,5 CM / TOTAL LENGTH: 26,1 CM

4522/14 / 4002293452210



UTILITY KNIFE

WEIGHT: 115 G / BLADE LENGTH: 16 CM / BLADE WIDTH: 2,5 CM / TOTAL LENGTH: 28,3 CM

4522/16 / 4002293452227



UTILITY KNIFE

WEIGHT: 120 G / BLADE LENGTH: 18 CM / BLADE WIDTH: 2,5 CM / TOTAL LENGTH: 30,1 CM

4522/18 / 4002293452234



CARVING KNIFE

WEIGHT: 166 G / BLADE LENGTH: 20 CM / BLADE WIDTH: 3,1 CM / TOTAL LENGTH: 32,9 CM

4522/20 / 4002293452241



CARVING KNIFE

WEIGHT: 173 G / BLADE LENGTH: 23 CM / BLADE WIDTH: 3,1 CM / TOTAL LENGTH: 35,9 CM

4522/23 / 4002293452258



LONG SLICER

WEIGHT: 183 G / BLADE LENGTH: 26 CM / BLADE WIDTH: 3,1 CM / TOTAL LENGTH: 38,7 CM

4522/26 / 4002293452265



CARVING KNIFE

WEIGHT: 163 G / BLADE LENGTH: 20 CM / BLADE WIDTH: 3,1 CM / TOTAL LENGTH: 32,5 CM / WITH HOLLOW EDGE

4524/20 / 4002293452418



CARVING KNIFE

WEIGHT: 171 G / BLADE LENGTH: 23 CM / BLADE WIDTH: 3,1 CM / TOTAL LENGTH: 35,6 CM / WITH HOLLOW EDGE

4524/23 / 4002293452425



SERRATED SLICER

WEIGHT: 181 G / BLADE LENGTH: 23 CM / BLADE WIDTH: 3,1 CM / TOTAL LENGTH: 35,6 CM / WITH SERRATED EDGE

4523/23 / 4002293452326



HAM SLICER

WEIGHT: 131 G / BLADE LENGTH: 26 CM / BLADE WIDTH: 2,5 CM / TOTAL LENGTH: 38,1 CM

4530 / 4002293453002



HAM SLICER

WEIGHT: 126 G / BLADE LENGTH: 26 CM / BLADE WIDTH: 2,5 CM / TOTAL LENGTH: 38,1 CM / WITH HOLLOW EDGE

4531 / 4002293453101



SUPER SLICER

WEIGHT: 218 G / BLADE LENGTH: 26 CM / BLADE WIDTH: 4,15 CM / TOTAL LENGTH: 38,4 CM / WITH WAVY EDGE

4532 / 4002293453200



CONFECTIONER'S KNIFE

WEIGHT: 195 G / BLADE LENGTH: 26 CM / BLADE WIDTH: 3,1 CM / TOTAL LENGTH: 40,4 CM / WITH SERRATED EDGE

4514 / 4002293451404



CHEESE KNIFE

WEIGHT: 124 G / BLADE LENGTH: 14 CM / BLADE WIDTH: 3,41 CM / TOTAL LENGTH: 24,7 CM

3103 / 4002293310305



CHEESE KNIFE

WEIGHT: 119 G / BLADE LENGTH: 14 CM / BLADE WIDTH: 2,55 CM / TOTAL LENGTH: 25,9 CM / GELOCHT

3102 / 4002293310206



KITCHEN KNIFE

WEIGHT: 119 G / BLADE LENGTH: 16 CM / BLADE WIDTH: 2,5 CM / TOTAL LENGTH: 28,3 CM

4138/16 / 4002293413815



KITCHEN KNIFE

WEIGHT: 117 G / BLADE LENGTH: 16 CM / BLADE WIDTH: 2,5 CM / TOTAL LENGTH: 28,3 CM / WITH HOLLOW EDGE

4139/16 / 4002293413914



SALMON SLICER

WEIGHT: 127 G
BLADE LENGTH: 32 CM
BLADE WIDTH: 2,5 CM
TOTAL LENGTH: 44 CM
FLEXIBLE

4542 / 4002293454207

SALMON SLICER

WEIGHT: 123 G
BLADE LENGTH: 32 CM
BLADE WIDTH: 2,5 CM
TOTAL LENGTH: 44 CM
FLEXIBLE / WITH HOLLOW EDGE

4543 / 4002293454306

COOK'S KNIFE

WEIGHT: 408 G
BLADE LENGTH: 32 CM
BLADE WIDTH: 5,6 CM
TOTAL LENGTH: 45,2 CM

4582/32 / 4002293458274

COOK'S KNIFE

WEIGHT: 756 G
BLADE LENGTH: 36 CM
BLADE WIDTH: 7,1 CM
TOTAL LENGTH: 50,3 CM
EXTRA HEAVY

4586/36 / 4002293458625



PARING KNIFE

WEIGHT: 62 G / BLADE LENGTH: 9 CM / BLADE WIDTH: 2 CM / TOTAL LENGTH: 18,8 CM / HALF BOLSTER

4065/09 / 4002293406510



COOK'S KNIFE

WEIGHT: 139 G / BLADE LENGTH: 16 CM / BLADE WIDTH: 4 CM / TOTAL LENGTH: 28 CM / HALF BOLSTER

4581/16 / 4002293458120



COOK'S KNIFE

WEIGHT: 215 G / BLADE LENGTH: 20 CM / BLADE WIDTH: 4,7 CM / TOTAL LENGTH: 33,1 CM / HALF BOLSTER

4581/20 / 4002293458144



COOK'S KNIFE

WEIGHT: 225 G / BLADE LENGTH: 23 CM / BLADE WIDTH: 4,7 CM / TOTAL LENGTH: 36,1 CM / HALF BOLSTER

4581/23 / 4002293458151



CHAI DAO

WEIGHT: 219 G / BLADE LENGTH: 17 CM / BLADE WIDTH: 5,58 CM / TOTAL LENGTH: 29,4 CM / HALF BOLSTER

4177 / 4002293417707



CHAI DAO

WEIGHT: 217 G / BLADE LENGTH: 17 CM / BLADE WIDTH: 5,58 CM / TOTAL LENGTH: 29,4 CM / HALF BOLSTER / WITH HOLLOW EDGE

8888 / 4002293888804



NAKIRI

WEIGHT: 178 G / BLADE LENGTH: 17 CM / BLADE WIDTH: 4,72 CM / TOTAL LENGTH: 29 CM / HALF BOLSTER / WITH HOLLOW EDGE

4193 / 4002293419305



SANTOKU

WEIGHT: 121 G / BLADE LENGTH: 14 CM / BLADE WIDTH: 4,1 CM / TOTAL LENGTH: 25,5 CM / HALF BOLSTER / WITH HOLLOW EDGE

4182 / 4002293418209



SANTOKU

WEIGHT: 176 G / BLADE LENGTH: 17 CM / BLADE WIDTH: 4,59 CM / TOTAL LENGTH: 30,3 CM / HALF BOLSTER / WITH HOLLOW EDGE

4183 / 4002293418308



SANTOKU

WEIGHT: 178 G / BLADE LENGTH: 17 CM / BLADE WIDTH: 4,59 CM / TOTAL LENGTH: 30,3 CM / HALF BOLSTER

4181 / 4002293418100



CHINESE CHEF'S KNIFE

WEIGHT: 322 G / BLADE LENGTH: 18 CM / BLADE WIDTH: 7,7 CM / TOTAL LENGTH: 31,7 CM

4686/18 / 4002293468617



BUTCHER KNIFE

WEIGHT: 241 G / BLADE LENGTH: 20 CM / BLADE WIDTH: 4,7 CM / TOTAL LENGTH: 33,7 CM / WITH HOLLOW EDGE

4657-1/20 / 4002293465746



HACKMESSER

WEIGHT: 490 G / BLADE LENGTH: 16 CM / BLADE WIDTH: 7 CM / TOTAL LENGTH: 29,7 CM / SPINE WIDTH: 3,7 MM

4682/16 / 4002293468242



SUPER GLIDER

WEIGHT: 264 G / BLADE LENGTH: 20 CM / BLADE WIDTH: 4,7 CM / TOTAL LENGTH: 33,6 CM / PERFORATED, WITH DEFLECTING RIDGE

4563/20 / 4002293456317



MAGNETIC HOLDER

WEIGHT: 1.400 G / MATERIAL: WALNUT / L 50 CM x W 2 CM x H 6,3 CM

7222/50 / 4002293572222



Knives not included.

Dynamic tool for professionals and athletic performers



Santoku

OPTIMUM FUNCTIONALITY. ERGONOMIC DESIGN.

Sharp, versatile, easy to clean – the GRAND PRIX II knives combine stylish aesthetics with unlimited functionality and athletic qualities. This makes the series popular with any cooks who need completely reliable tools at all times.

The blades are extremely sharp and are characterised by a high level of resilience and durability. The easy to clean and slip-resistant plastic handle from forged steel provides excellent balance and ensures safe handling, while the seamless transition between handle and blade guarantees impeccable hygiene, and the knives are also dishwasher safe.





Grand Prix II Santoku

Forged from one piece of stainless steel

Half bolster design for optimal weight balance

Sleekly embedded logo in the handle



Grind angle 20° / final buffing by hand

Handle made from dishwasher-safe, glass fibre re-enforced special synthetic material



FULL BOLSTER

The full bolster reliably protects the fingers in everyday cooking and the balance makes agile and precision work easier.



HANDLE

The handle made from black synthetic material feels comfortable to hold. The knives are optimally balanced and therefore guarantee relaxed work.



TOMATO KNIFE

The fine serrated edge of the tomato knife cuts smoothly through the solid tomato skin, the forked tip picks up the slices. The knife is also well-suited to cheese and fruits.



HOLLOW EDGE

Small air pockets are produced by the hollow edge on the depressions of the blade. The positive effect of this is that thin or soft food items are more easily removed from the blade during use.

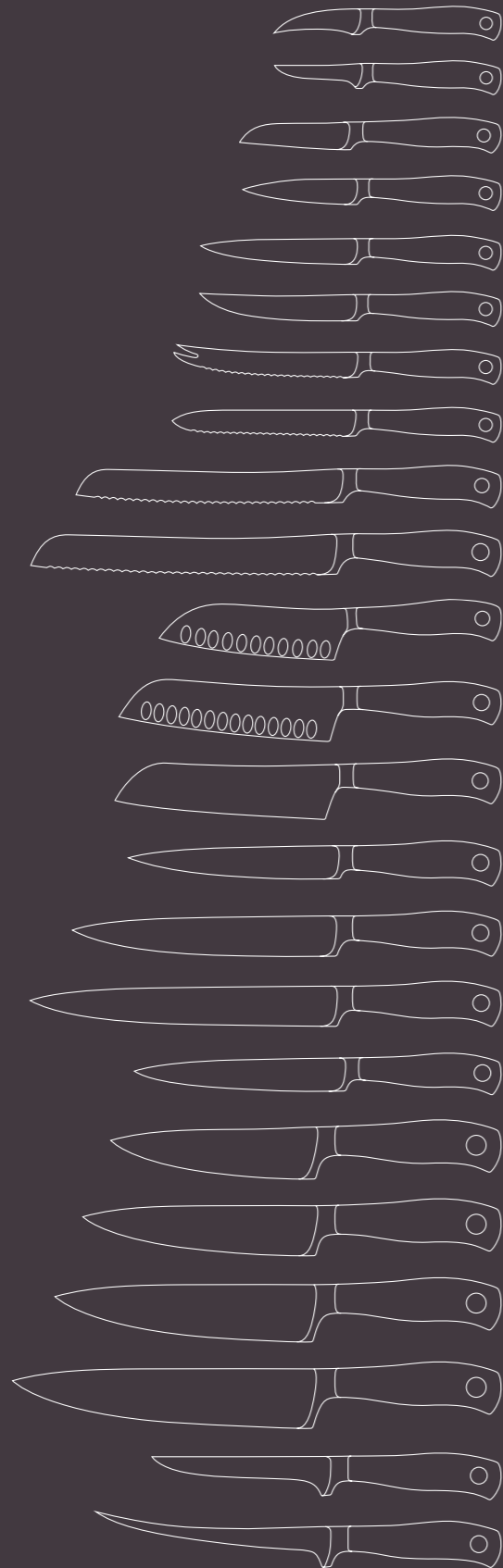

PEELING KNIFE

WEIGHT: 52 G / BLADE LENGTH: 7 CM / BLADE WIDTH: 2 CM / TOTAL LENGTH: 18,1 CM

4025 / 4002293402505



PARING KNIFE

WEIGHT: 55 G / BLADE LENGTH: 8 CM / BLADE WIDTH: 2 CM / TOTAL LENGTH: 19,1 CM

4015 / 4002293401508



PARING KNIFE

WEIGHT: 55 G / BLADE LENGTH: 9 CM / BLADE WIDTH: 2 CM / TOTAL LENGTH: 20 CM

4040/09 / 4002293404011



UTILITY KNIFE

WEIGHT: 59 G / BLADE LENGTH: 12 CM / BLADE WIDTH: 2 CM / TOTAL LENGTH: 23,1 CM

4040/12 / 4002293404035



STEAK KNIFE

WEIGHT: 60 G / BLADE LENGTH: 12 CM / BLADE WIDTH: 2 CM / TOTAL LENGTH: 23,1 CM

4048 / 4002293404806



SAUSAGE KNIFE

WEIGHT: 62 G / BLADE LENGTH: 12 CM / BLADE WIDTH: 2 CM / TOTAL LENGTH: 25 CM / WITH SERRATED EDGE

4106 / 4002293410609



BONING KNIFE

WEIGHT: 122 G / BLADE LENGTH: 14 CM / BLADE WIDTH: 3,1 CM / TOTAL LENGTH: 27,3 CM

4615 / 4002293461502



FILLET KNIFE

WEIGHT: 118 G / BLADE LENGTH: 18 CM / BLADE WIDTH: 3,1 CM / TOTAL LENGTH: 30,9 CM / FLEXIBLE

4625 / 4002293462509



UTILITY KNIFE

WEIGHT: 100 G / BLADE LENGTH: 16 CM / BLADE WIDTH: 2,5 CM / TOTAL LENGTH: 28,4 CM

4525/16 / 4002293452524



CARVING KNIFE

WEIGHT: 162 G / BLADE LENGTH: 20 CM / BLADE WIDTH: 3,1 CM / TOTAL LENGTH: 33,2 CM

4525/20 / 4002293452548



BREAD KNIFE

WEIGHT: 115 G / BLADE LENGTH: 20 CM / BLADE WIDTH: 2,5 CM / TOTAL LENGTH: 32,3 CM / WITH SERRATED EDGE

4155 / 4002293415505



BREAD KNIFE

WEIGHT: 163 G / BLADE LENGTH: 23 CM / BLADE WIDTH: 3,1 CM / TOTAL LENGTH: 36,9 CM / WITH SERRATED EDGE

4165 / 4002293416502



SANTOKU

WEIGHT: 101 G / BLADE LENGTH: 14 CM / BLADE WIDTH: 4,1 CM / TOTAL LENGTH: 25,7 CM / WITH HOLLOW EDGE

4173 / 4002293417301



SANTOKU

WEIGHT: 176 G / BLADE LENGTH: 17 CM / BLADE WIDTH: 4,6 CM / TOTAL LENGTH: 30,5 CM / WITH HOLLOW EDGE

4175 / 4002293417509



SANTOKU

WEIGHT: 179 G / BLADE LENGTH: 17 CM / BLADE WIDTH: 4,6 CM / TOTAL LENGTH: 30,5 CM

4174 / 4002293417400



COOK'S KNIFE

WEIGHT: 148 G / BLADE LENGTH: 16 CM / BLADE WIDTH: 4 CM / TOTAL LENGTH: 28,7 CM

4585/16 / 4002293458526



COOK'S KNIFE

WEIGHT: 159 G / BLADE LENGTH: 18 CM / BLADE WIDTH: 4 CM / TOTAL LENGTH: 30,7 CM

4585/18 / 4002293458533



COOK'S KNIFE

WEIGHT: 259 G / BLADE LENGTH: 20 CM / BLADE WIDTH: 4,7 CM / TOTAL LENGTH: 34,1 CM

4585/20 / 4002293458540



COOK'S KNIFE

WEIGHT: 265 G / BLADE LENGTH: 23 CM / BLADE WIDTH: 4,7 CM / TOTAL LENGTH: 37,1 CM

4585/23 / 4002293458557



MAGNETIC HOLDER

WEIGHT: 386 G / MATERIAL: ALUMINIUM / L 46 CM x W 2,6 CM x H 4 CM

7227/45 / 4002293722719



Knives not included.

Light. Sharp. Versatile.
The handy series for getting started in the kitchen.



Cook's knife

AN AGILE ALL-ROUNDER

The blade of each GOURMET knife is cut from stainless steel plates with a precision laser and then processed in 35 manufacturing stages. Thanks to their extremely high degree of hardness of 56° HRC, they are comparable with the quality and sharpness of forged knives.

Thanks to their lighter weight and unique ergonomics they are very comfortable to hold, extremely well-balanced and facilitate cutting which is both robust and easy on the hands and wrists. The handles made from special synthetic material are triple-riveted, dishwasher-safe and therefore exceptionally hygienic.

The GOURMET series impresses with an excellent price-performance ratio and, with more than 40 different items, is just as useful for domestic households as a starter set or as basic equipment for the professional kitchen.





Gourmet Cook's knife

Blades cut using precision lasers

Seamlessly moulded handle

Triple riveted



Grinding angle 28° / final buffing by hand

Light weight for agile handling

Full tang

Hand guard



HAND GUARD

The knife handle sits well in the palm and curves into the hand to prevent slipping. The robust handle shells are secured with stainless steel rivets and processed seamlessly.



FULL TANG

As an extension of the blade, the tang gives the knife a reliable stability. In addition, it ensures balance as a counterweight to the blade.



TOMATO KNIFE

The fine serrated edge of the tomato knife cuts smoothly through the firm tomato skin, while the split tip picks up the slices. The knife is also well suited to cheese and fruits.



WAVY EDGE

The wavy edge formed from the inside out produces a clean cut and is well-suited for large fruits, vegetables or roasts. With the broad, long blade, it is also perfectly suited to bread and cakes.



DECORATING KNIFE

The special blade for decorative cutting of raw and cooked fruits and vegetables or to neatly portion out butter is perfectly suited for cooks with a creative flair.

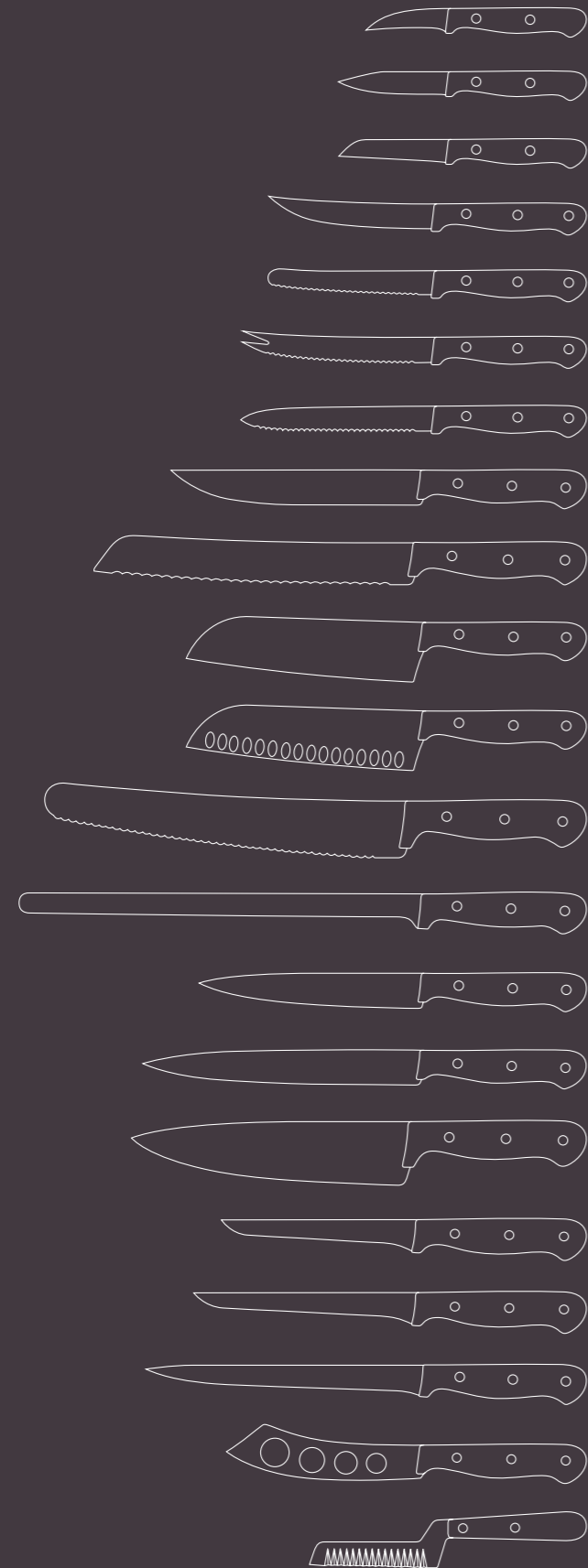

PEELING KNIFE

WEIGHT: 32 G / BLADE LENGTH: 6 CM / BLADE WIDTH: 1,7 CM / TOTAL LENGTH: 16,2 CM

4034 / 4002293403403



PARING KNIFE

WEIGHT: 35 G / BLADE LENGTH: 8 CM / BLADE WIDTH: 1,7 CM / TOTAL LENGTH: 18,2 CM

4010/08 / 4002293401027



PARING KNIFE

WEIGHT: 39 G / BLADE LENGTH: 9 CM / BLADE WIDTH: 1,7 CM / TOTAL LENGTH: 19,2 CM

4010/09 / 4002293401034



PARING KNIFE

WEIGHT: 35 G / BLADE LENGTH: 8 CM / BLADE WIDTH: 1,7 CM / TOTAL LENGTH: 18,2 CM / WITH SERRATED EDGE

4011 / 4002293401102



PARING KNIFE

WEIGHT: 39 G / BLADE LENGTH: 8 CM / BLADE WIDTH: 1,7 CM / TOTAL LENGTH: 18,2 CM

4022 / 4002293402208



PARING KNIFE

WEIGHT: 34 G / BLADE LENGTH: 8 CM / BLADE WIDTH: 1,7 CM / TOTAL LENGTH: 18 CM

4042 / 4002293404202



PARING KNIFE

WEIGHT: 36 G / BLADE LENGTH: 10 CM / BLADE WIDTH: 1,7 CM / TOTAL LENGTH: 20,2 CM

4060 / 4002293406008



UTILITY KNIFE

WEIGHT: 53 G / BLADE LENGTH: 12 CM / BLADE WIDTH: 1,9 CM / TOTAL LENGTH: 23,4 CM

4045 / 4002293404509



DECORATING KNIFE

WEIGHT: 68 G / BLADE LENGTH: 10 CM / BLADE WIDTH: 1,8 CM / TOTAL LENGTH: 21,6 CM

4204 / 4002293420400

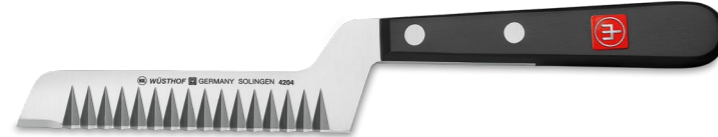

STEAK KNIFE

WEIGHT: 53 G / BLADE LENGTH: 12 CM / BLADE WIDTH: 1,9 CM / TOTAL LENGTH: 23,3 CM

4050 / 4002293405001



SAUSAGE KNIFE

WEIGHT: 59 G / BLADE LENGTH: 14 CM / BLADE WIDTH: 1,9 CM / TOTAL LENGTH: 25,1 CM / WITH SERRATED EDGE

4107 / 4002293410708



BRUNCH KNIFE

WEIGHT: 57 G / BLADE LENGTH: 12 CM / BLADE WIDTH: 1,9 CM / TOTAL LENGTH: 23,4 CM / WITH SERRATED EDGE

4101 / 4002293410104



TOMATO KNIFE

WEIGHT: 60 G / BLADE LENGTH: 14 CM / BLADE WIDTH: 1,9 CM / TOTAL LENGTH: 25,4 CM / WITH SERRATED EDGE

4105 / 4002293410500



CHEESE KNIFE

WEIGHT: 93 G / BLADE LENGTH: 14 CM / BLADE WIDTH: 2,6 CM / TOTAL LENGTH: 26,8 CM / PERFORATED

3108 / 4002293310879



BREAD KNIFE

WEIGHT: 108 G / BLADE LENGTH: 20 CM / BLADE WIDTH: 2,6 CM / TOTAL LENGTH: 32,4 CM / WITH SERRATED EDGE

4143 / 4002293414300



BREAD KNIFE

WEIGHT: 140 G / BLADE LENGTH: 23 CM / BLADE WIDTH: 3,1 CM / TOTAL LENGTH: 35,8 CM / WITH SERRATED EDGE

4145 / 4002293414508



COOK'S KNIFE

WEIGHT: 104 G / BLADE LENGTH: 14 CM / BLADE WIDTH: 4,2 CM / TOTAL LENGTH: 26,7 CM

4562/14 / 4002293456201



COOK'S KNIFE

WEIGHT: 134 G / BLADE LENGTH: 16 CM / BLADE WIDTH: 4,2 CM / TOTAL LENGTH: 29,1 CM

4562/16 / 4002293456218



COOK'S KNIFE

WEIGHT: 133 G / BLADE LENGTH: 18 CM / BLADE WIDTH: 4,2 CM / TOTAL LENGTH: 31 CM

4562/18 / 4002293456225



COOK'S KNIFE

WEIGHT: 184 G / BLADE LENGTH: 20 CM / BLADE WIDTH: 4,7 CM / TOTAL LENGTH: 33,6 CM

4562/20 / 4002293456232



COOK'S KNIFE

WEIGHT: 196 G / BLADE LENGTH: 23 CM / BLADE WIDTH: 4,7 CM / TOTAL LENGTH: 36,4 CM

4562/23 / 4002293456249



COOK'S KNIFE

WEIGHT: 206 G / BLADE LENGTH: 26 CM / BLADE WIDTH: 4,7 CM / TOTAL LENGTH: 39,4 CM

4562/26 / 4002293456256



FISH FILLET KNIFE

WEIGHT: 99 G / BLADE LENGTH: 20 CM / BLADE WIDTH: 2,4 CM / TOTAL LENGTH: 34,1 CM / FLEXIBLE

4618 / 4002293461816



FILLET KNIFE

WEIGHT: 80 G / BLADE LENGTH: 16 CM / BLADE WIDTH: 2,6 CM / TOTAL LENGTH: 28,6 CM / FLEXIBLE

4552 / 4002293455204



SUPER SLICER

WEIGHT: 180 G / BLADE LENGTH: 26 CM / BLADE WIDTH: 4,1 CM / TOTAL LENGTH: 39,2 CM / WITH WAVY EDGE

4519 / 4002293451916



CONFECTIONER'S KNIFE

WEIGHT: 180 G / BLADE LENGTH: 26 CM / BLADE WIDTH: 4,1 CM / TOTAL LENGTH: 39,2 CM / WITH SERRATED EDGE

4517 / 4002293451701



SALMON SLICER

WEIGHT: 97 G / BLADE LENGTH: 29 CM / BLADE WIDTH: 2,05 CM / TOTAL LENGTH: 42,3 CM / FLEXIBLE

4540 / 4002293454009



SALMON SLICER

WEIGHT: 96 G / BLADE LENGTH: 29 CM / BLADE WIDTH: 2,05 CM / TOTAL LENGTH: 42,3 CM / FLEXIBLE / WITH HOLLOW EDGE

4541 / 4002293454108



UTILITY KNIFE

WEIGHT: 89 G / BLADE LENGTH: 16 CM / BLADE WIDTH: 2,6 CM / TOTAL LENGTH: 28,5 CM

4114/16 / 4002293411408



SLICER

WEIGHT: 103 G / BLADE LENGTH: 20 CM / BLADE WIDTH: 2,6 CM / TOTAL LENGTH: 32,5 CM

4114/20 / 4002293411415



ROAST BEEF SLICER

WEIGHT: 148 G / BLADE LENGTH: 26 CM / BLADE WIDTH: 2,95 CM / TOTAL LENGTH: 39,1 CM / WITH SERRATED EDGE

4513/26 / 4002293451312



ROAST BEEF SLICER

WEIGHT: 163 G / BLADE LENGTH: 32 CM / BLADE WIDTH: 2,95 CM / TOTAL LENGTH: 44,6 CM / WITH SERRATED EDGE

4513/32 / 4002293451329



ROAST BEEF SLICER

WEIGHT: 146 G / BLADE LENGTH: 26 CM / BLADE WIDTH: 2,95 CM / TOTAL LENGTH: 38,9 CM / WITH HOLLOW EDGE

4511 / 4002293451107



ROAST BEEF SLICER

WEIGHT: 212 G / BLADE LENGTH: 32 CM / BLADE WIDTH: 4,1 CM / TOTAL LENGTH: 44,9 CM / WITH HOLLOW EDGE

4515/32 / 4002293451510



ROAST BEEF SLICER

WEIGHT: 213 G / BLADE LENGTH: 36 CM / BLADE WIDTH: 4,1 CM / TOTAL LENGTH: 49,5 CM / WITH HOLLOW EDGE

4515/36 / 4002293451527



BONING KNIFE

WEIGHT: 90 G / BLADE LENGTH: 14 CM / BLADE WIDTH: 2,4 CM / TOTAL LENGTH: 27,1 CM

4606/14 / 4002293460611



BONING KNIFE

WEIGHT: 94 G / BLADE LENGTH: 16 CM / BLADE WIDTH: 2,4 CM / TOTAL LENGTH: 29,1 CM

4606/16 / 4002293460628



BONING KNIFE

WEIGHT: 92 G / BLADE LENGTH: 16 CM / BLADE WIDTH: 2,4 CM / TOTAL LENGTH: 29,1 CM / FLEXIBLE

4607 / 4002293460703



KITCHEN KNIFE

WEIGHT: 88 G / BLADE LENGTH: 14 CM / BLADE WIDTH: 2,6 CM / TOTAL LENGTH: 26,5 CM

4130/14 / 4002293413013



KITCHEN KNIFE

WEIGHT: 91 G / BLADE LENGTH: 16 CM / BLADE WIDTH: 2,6 CM / TOTAL LENGTH: 28,5 CM

4130/16 / 4002293413020



KITCHEN KNIFE

WEIGHT: 95 G / BLADE LENGTH: 18 CM / BLADE WIDTH: 2,6 CM / TOTAL LENGTH: 30,5 CM

4130/18 / 4002293413037



SANTOKU

WEIGHT: 117 G / BLADE LENGTH: 17 CM / BLADE WIDTH: 4,4 CM / TOTAL LENGTH: 29,5 CM

4186 / 4002293418605



SANTOKU

WEIGHT: 114 G / BLADE LENGTH: 17 CM / BLADE WIDTH: 4,4 CM / TOTAL LENGTH: 29,5 CM / WITH HOLLOW EDGE

4188 / 4002293418803



KNIFE BLOCK

WEIGHT: 1,48 KG / MATERIAL: BUCHE / W 26 CM x H 21,3 CM x D 8,7 CM

7235 / 4002293723518



Knives not included.

Knives for new-comers to the kitchen, which can be relied upon to overcome all challenges



Brunch knife

SHARP, LONG-LASTING, EFFORTLESS - FOR ALL CUTTING WORK

The SILVERPOINT knife blades are cut from special stainless steel using a precision laser. Using our tried and tested technical know-how gained from over 200 years of WÜSTHOF experience, they are then processed into sturdy starter knives for young cooks. With their optimum sharpness, the knives cut cleanly through any foodstuff and have an impressively long lifespan.

The special synthetic black handles are seamlessly assembled, dishwasher-safe and therefore exceptionally hygienic. The knives are optimally balanced, comfortable to hold and so guarantee effortless work.





Silverpoint Brunch knife

Blades cut with precision laser

Handle made from special synthetic material / Dishwasher safe



Rounded tip

Serrated edge

Blades made from special stainless steel

Embedded logo in the handle



HANDLE

The handle made from black special synthetic material with logo provides a comfortable feel in the hand and supports effortless work.



HOLLOW EDGE

Small air bubbles are produced in the depressions by the hollow edge. The positive effect of this is that thin or soft food items can be removed from the blade more easily during use.



SERRATED EDGE

With its robust serrated edge, the Brunch Knife cuts every tomato into fine slices – and the same goes for most kinds of vegetables, soft fruits with solid skin or also bread, rolls and cured sausage.

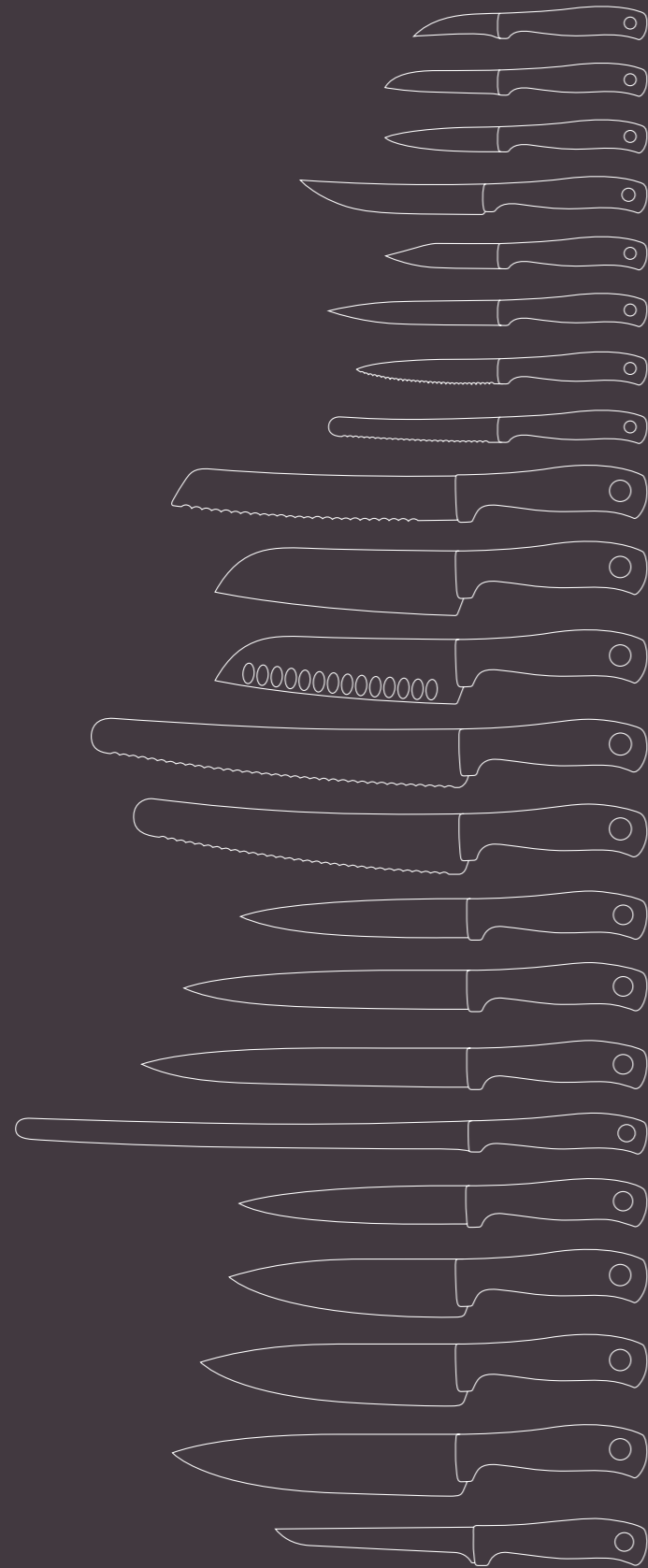

PEELING KNIFE

WEIGHT: 22 G / BLADE LENGTH: 6 CM / BLADE WIDTH: 1,75 CM / TOTAL LENGTH: 16,6 CM

4033 / 4002293403304



PARING KNIFE

WEIGHT: 27 G / BLADE LENGTH: 8 CM / BLADE WIDTH: 1,75 CM / TOTAL LENGTH: 18,5 CM

4013 / 4002293401300



PARING KNIFE

WEIGHT: 23 G / BLADE LENGTH: 8 CM / BLADE WIDTH: 1,75 CM / TOTAL LENGTH: 18,6 CM

4043 / 4002293404301



PARING KNIFE

WEIGHT: 24 G / BLADE LENGTH: 8 CM / BLADE WIDTH: 1,75 CM / TOTAL LENGTH: 18,6 CM

4023 / 4002293402307



PARING KNIFE

WEIGHT: 33 G / BLADE LENGTH: 10 CM / BLADE WIDTH: 1,75 CM / TOTAL LENGTH: 20,5 CM / WITH SERRATED EDGE

4052 / 4002293405209



UTILITY KNIFE

WEIGHT: 28 G / BLADE LENGTH: 12 CM / BLADE WIDTH: 1,75 CM / TOTAL LENGTH: 22,6 CM

4051 / 4002293405100



STEAK KNIFE

WEIGHT: 49 G / BLADE LENGTH: 13 CM / BLADE WIDTH: 2,15 CM / TOTAL LENGTH: 24,6 CM

4041 / 4002293404103



BRUNCH KNIFE

WEIGHT: 30 G / BLADE LENGTH: 12 CM / BLADE WIDTH: 1,75 CM / TOTAL LENGTH: 22,7 CM / WITH SERRATED EDGE

4103 / 4002293410302



BONING KNIFE

WEIGHT: 60 G / BLADE LENGTH: 14 CM / BLADE WIDTH: 2,59 CM / TOTAL LENGTH: 27 CM

4605 / 4002293460505



FILLET KNIFE

WEIGHT: 62 G / BLADE LENGTH: 16 CM / BLADE WIDTH: 2,59 CM / TOTAL LENGTH: 27,7 CM / FLEXIBLE

4551 / 4002293455105



BREAD KNIFE

WEIGHT: 85 G / BLADE LENGTH: 20 CM / BLADE WIDTH: 2,6 CM / TOTAL LENGTH: 32,2 CM / WITH SERRATED EDGE

4141 / 4002293414102



CONFECTIONER'S KNIFE

WEIGHT: 140 G / BLADE LENGTH: 23 CM / BLADE WIDTH: 4,1 CM / TOTAL LENGTH: 35,9 CM / WITH SERRATED EDGE

4501/23 / 4002293450100



CONFECTIONER'S KNIFE

WEIGHT: 155 G / BLADE LENGTH: 26 CM / BLADE WIDTH: 4,1 CM / TOTAL LENGTH: 38,9 CM / WITH SERRATED EDGE

4501/26 / 4002293450117



COOK'S KNIFE

WEIGHT: 81 G / BLADE LENGTH: 16 CM / BLADE WIDTH: 3,67 CM / TOTAL LENGTH: 28,2 CM

4561/16 / 4002293456102



COOK'S KNIFE

WEIGHT: 124 G / BLADE LENGTH: 18 CM / BLADE WIDTH: 4,17 CM / TOTAL LENGTH: 30,6 CM

4561/18 / 4002293456133



COOK'S KNIFE

WEIGHT: 147 G / BLADE LENGTH: 20 CM / BLADE WIDTH: 4,17 CM / TOTAL LENGTH: 32,6 CM

4561/20 / 4002293456157



COOK'S KNIFE

WEIGHT: 155 G / BLADE LENGTH: 23 CM / BLADE WIDTH: 4,17 CM / TOTAL LENGTH: 35,6 CM

4561/23 / 4002293456188



COOK'S KNIFE

WEIGHT: 173 G / BLADE LENGTH: 26 CM / BLADE WIDTH: 4,17 CM / TOTAL LENGTH: 38,6 CM

4561/26 / 4002293456195



SLICER

WEIGHT: 70 G / BLADE LENGTH: 16 CM / BLADE WIDTH: 2,6 CM / TOTAL LENGTH: 28,2 CM

4510/16 / 4002293451022



SLICER

WEIGHT: 79 G / BLADE LENGTH: 20 CM / BLADE WIDTH: 2,6 CM / TOTAL LENGTH: 32,2 CM

4510/20 / 4002293451008



SALMON SLICER

WEIGHT: 75 G / BLADE LENGTH: 29 CM / BLADE WIDTH: 2,6 CM / TOTAL LENGTH: 42,5 CM / FLEXIBLE

4544 / 4002293454405



SANTOKU

WEIGHT: 99 G / BLADE LENGTH: 17 CM / BLADE WIDTH: 4,44 CM / TOTAL LENGTH: 29,4 CM

4180 / 4002293418001



SANTOKU

WEIGHT: 98 G / BLADE LENGTH: 17 CM / BLADE WIDTH: 4,44 CM / TOTAL LENGTH: 29,4 CM / WITH HOLLOW EDGE

4184 / 4002293418414



CHINESE CHEF'S KNIFE

WEIGHT: 240 G / BLADE LENGTH: 18 CM / BLADE WIDTH: 7,7 CM / TOTAL LENGTH: 31,5 CM

4692/18 / 4002293469201



CHINESE CHEF'S KNIFE

WEIGHT: 260 G / BLADE LENGTH: 20 CM / BLADE WIDTH: 7,7 CM / TOTAL LENGTH: 33,5 CM

4692/20 / 4002293469218



CLEAVER

WEIGHT: 360 G / BLADE LENGTH: 16 CM / BLADE WIDTH: 7,1 CM / TOTAL LENGTH: 28,9 CM / SPINE WIDTH: 3,5 MM

4684/16 / 4002293468440



KNIFE BLOCK

WEIGHT: 2,5 KG / MATERIAL: ASH WOOD, BLACK / W 25,5 CM x H 21,4 CM x D 15,6 CM

7264 / 4002293726403



Knives not included.

Cleaver

CLASSIC

WEIGHT: 490 G / BLADE LENGTH: 16 CM / BLADE WIDTH: 7 CM / TOTAL LENGTH: 29,7 CM / SPINE WIDTH: 3,5 MM

4682/16 / 4002293468242



SILVERPOINT

WEIGHT: 360 G / BLADE LENGTH: 18 CM / BLADE WIDTH: 7,1 CM / TOTAL LENGTH: 28,9 CM / SPINE WIDTH: 3,5 MM

4684/16 / 4002293468440



4680/16 / 4002293468013

WEIGHT: 460 G / BLADE LENGTH: 16 CM / BLADE WIDTH: 7 CM / TOTAL LENGTH: 29,5 CM / SPINE WIDTH: 3,5 MM



4680/18 / 4002293468020 / WEIGHT: 590 G / BLADE LENGTH: 18 CM / BLADE WIDTH: 7,4 CM / TOTAL LENGTH: 31,5 CM / SPINE WIDTH: 4 MM

4680/20 / 4002293468037 / WEIGHT: 680 G / BLADE LENGTH: 20 CM / BLADE WIDTH: 7,8 CM / TOTAL LENGTH: 33,5 CM / SPINE WIDTH: 4 MM



Cleaver

4685/16 / 4002293468518

WEIGHT: 680 G / BLADE LENGTH: 16 CM / BLADE WIDTH: 7,3 CM / TOTAL LENGTH: 28,6 CM / SPINE WIDTH: 5 MM



4685/19 / 4002293468525

WEIGHT: 810 G / BLADE LENGTH: 19 CM / BLADE WIDTH: 8,2 CM / TOTAL LENGTH: 31,6 CM / SPINE WIDTH: 5 MM



4685/21 / 4002293468532

WEIGHT: 970 G / BLADE LENGTH: 21 CM / BLADE WIDTH: 8,5 CM / TOTAL LENGTH: 36,2 CM / SPINE WIDTH: 5 MM



4685/24 / 4002293468549

WEIGHT: 1100 G / BLADE LENGTH: 24 CM / BLADE WIDTH: 9,8 CM / TOTAL LENGTH: 39,3 CM / SPINE WIDTH: 5 MM



Chinese chef's knife

IKON

WEIGHT: 350 G / BLADE LENGTH: 18 CM / BLADE WIDTH: 7,75 CM / TOTAL LENGTH: 32,4 CM

4973/18 / 4002293497334



CLASSIC IKON

WEIGHT: 350 G / BLADE LENGTH: 18 CM / BLADE WIDTH: 7,75 CM / TOTAL LENGTH: 32,4 CM

4673/18 / 4002293467337



CLASSIC IKON

WEIGHT: 350 G / BLADE LENGTH: 18 CM / BLADE WIDTH: 7,75 CM / TOTAL LENGTH: 32,4 CM

4673-0/18 / 4002293267333



CLASSIC

WEIGHT: 322 G / BLADE LENGTH: 18 CM / BLADE WIDTH: 7,75 CM / TOTAL LENGTH: 31,7 CM

4686/18 / 4002293468617



ATTENTION:

Chinese chef's knives have been ground thin for the ultimate cutting performance. Chopping through bones will damage the fine edge.

Chinese chef's knife

SILVERPOINT

4692/18 / 4002293469201 / WEIGHT: 240 G / BLADE LENGTH: 18 CM / BLADE WIDTH: 7,7 CM / TOTAL LENGTH: 31,5 CM

4692/20 / 4002293469218 / WEIGHT: 260 G / BLADE LENGTH: 20 CM / BLADE WIDTH: 7,7 CM / TOTAL LENGTH: 33,5 CM



4688 / 4002293468808

WEIGHT: 270 G / BLADE LENGTH: 20 CM / BLADE WIDTH: 8,39 CM / TOTAL LENGTH: 32,6 CM



4691/18 / 4002293469119

WEIGHT: 220 G / BLADE LENGTH: 18 CM / BLADE WIDTH: 7,7 CM / TOTAL LENGTH: 30,7 CM



4691/20 / 4002293469126

WEIGHT: 240 G / BLADE LENGTH: 20 CM / BLADE WIDTH: 7,7 CM / TOTAL LENGTH: 32,7 CM



Cheese knife

CLASSIC

WEIGHT: 124 G / BLADE LENGTH: 14 CM / BLADE WIDTH: 3,41 CM / TOTAL LENGTH: 24,9 CM

3103 / 4002293310305



CLASSIC

WEIGHT: 119 G / BLADE LENGTH: 14 CM / BLADE WIDTH: 2,55 CM / TOTAL LENGTH: 25,9 CM / PERFORATED

3102 / 4002293310206



GOURMET

WEIGHT: 93 G / BLADE LENGTH: 14 CM / BLADE WIDTH: 2,6 CM / TOTAL LENGTH: 26,8 CM / PERFORATED

3108 / 4002293310879



4800 / 4002293480008

WEIGHT: 90 G / BLADE LENGTH: 12 CM / BLADE WIDTH: 2,3 CM / TOTAL LENGTH: 24,8 CM

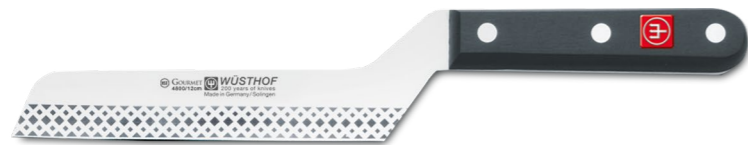

4802 / 4002293480206

WEIGHT: 150 G / BLADE LENGTH: 18 CM / BLADE WIDTH: 3 CM / TOTAL LENGTH: 33,2 CM



4812 / 4002293481203

WEIGHT: 350 G / BLADE LENGTH: 32 CM / BLADE WIDTH: 3 CM / TOTAL LENGTH: 65 CM / WITH DOUBLE HANDLE



Mincing knife

WITH SINGLE BLADE

4730 / 4002293473000 / WEIGHT: 98 G / TOTAL LENGTH: 14,1 CM

4731 / 4002293473109 / WEIGHT: 118 G / TOTAL LENGTH: 17,0 CM

4732 / 4002293473208 / WEIGHT: 210 G / TOTAL LENGTH: 21,9 CM



DOUBLE BLADED

4734 / 4002293473406 / WEIGHT: 148 G / TOTAL LENGTH: 14,0 CM

4735 / 4002293473505 / WEIGHT: 190 G / TOTAL LENGTH: 17,4 CM

4736 / 4002293473604 / WEIGHT: 322 G / TOTAL LENGTH: 21,5 CM



MINCING KNIFE SET

9881 / 4002293988108

CONTENT : MINCING KNIFE 4740 / MINCING BOARD 7281

WEIGHT: 855 G

MATERIAL: BEECH WOOD, BROWN

L 20 CM x B 20 CM x H 3 CM



4740 / 4002293474007

WEIGHT: 175 G / TOTAL LENGTH: 17,2 CM / WITH SINGLE BLADE





CHARCUTERIE SET

BOX MADE FROM HIGH-QUALITY BEECH WOOD WITH VELVET INLAY / WEIGHT: 1,1 KG / W 28 CM x H 18,5 CM x D 3,8 CM

9548 / 4002293954806

Made for connoisseurs

From fiery salami and meltingly smooth Camembert to refined pâtés – an expertly composed charcuterie selection is a culinary delight. The Charcuterie set contains three different knives to cut, spread or serve. All three knives captivate with handles made from warm, nuanced grained plum wood, which, as a genuine natural product, can also pleasingly vary in colour. Thanks to blades made from laser-cut steel and triple riveted handles, they are as robust as they are precise – made for enjoyable living.

CONTENT HOLZBOX

- SLICER** WEIGHT: 89 G / 14 CM / WITH SERRATED EDGE FOR SAUSAGE, HARD CHEESE AND BAGUETTES
- SPREADING KNIFE** WEIGHT: 91 G / 10 CM / WITH ROUND BLADE FOR MEAT PASTE, PATE OR EVEN AVOCADO
- CHEESE KNIFE** WEIGHT: 87 G / 14 CM / WITH BLADE PERFORATIONS FOR SOFT CHEESE AND CAMEMBERT



STEAK SET

BOX MADE FROM HIGH-QUALITY BEECH WOOD WITH VELVET INLAY / WEIGHT: 1,2 KG / W 28 CM x H 18,5 CM x D 3,8 CM

9534 / 4002293953403

Blades for connoisseurs

Perfection in the enjoyment of meat: The Steak set includes four knives of the highest quality from Solingen. Their handles made from warm, nuanced grained plum wood make them something special to look at – and their extra wide blades made from laser-cut steel and the triple riveted handle shells ensure precision and durability.

CONTENT OF WOODEN BOX

- 4 STEAK KNIVES** WEIGHT: 89 G / 14 CM / WITH EXTRA WIDE BLADE SHAPE



Crafter

STEAK KNIFE SET / WITH 4 CRAFTER KNIVES

9738 / 4002293097381

CONTENT

STEAK KNIFE / 12 CM



Urban Farmer

STEAK KNIFE SET / WITH 4 URBAN FARMER KNIVES

9401 / 4002293940106

CONTENT

STEAK KNIFE / 12 CM



Epicure

STEAK KNIFE SET / WITH 4 EPICURE KNIVES

9668 / 4002293966809

CONTENT

3968 STEAK KNIFE / 12 CM



KNIFE SET / WITH 2 EPICURE KNIVES

9682 / 4002293968209

CONTENT

3966/09 PARING KNIFE / 9 CM
3982/20 COOK'S KNIFE / 20 CM



Ikon

STEAK KNIFE SET / WITH 4 IKON KNIVES

9706 / 4002293970608

CONTENT

4988 STEAK KNIFE / 12 CM



KNIFE SET / WITH 3 IKON KNIVES

9600 / 4002293960005

CONTENT

4986/09 PARING KNIFE / 9 CM
4906/20 CARVING KNIFE / 20 CM
4996/20 COOK'S KNIFE / 20 CM



Classic Ikon

STEAK KNIFE SET / WITH 4 CLASSIC IKON KNIVES

9716 / 4002293971605

CONTENT

4096 STEAK KNIFE / 12 CM



KNIFE SET / WITH 3 CLASSIC IKON KNIVES

9601 / 4002293960104

CONTENT

4086/09 PARING KNIFE / 9 CM
4506/20 CARVING KNIFE / 20 CM
4596/20 COOK'S KNIFE / 20 CM



Classic Ikon

KNIFE SET / WITH 2 CLASSIC IKON KNIVES

9606 / 4002293960609

CONTENT

4086/09 PARING KNIFE / 9 CM
4596/20 COOK'S KNIFE / 20 CM



KNIFE SET / WITH 2 CLASSIC IKON KNIVES

9276 / 4002293927602

CONTENT

4006 PARING KNIFE / 8 CM
4176 SANTOKU / 17 CM



CARVING SET / WITH 2 CLASSIC IKON PIECES

9647 / 4002293964706

CONTENT

4506/20 CARVING KNIFE / 20 CM
4414/16 MEAT FORK / 16 CM



KNIFE SET / WITH 2 PIECES

9283 / 4002293928302

CONTENT

4673/18 CHINESE CHEF'S KNIFE / 18 CM
4348 KNIFE SHARPENER



Classic Ikon

STEAK KNIFE SET / WITH 4 CLASSIC IKON KNIVES

9716-0 / 4002293271606

CONTENT

4096-0 STEAK KNIFE / 12 CM



KNIFE SET / WITH 3 CLASSIC IKON KNIVES

9601-0 / 4002293260105

CONTENT

4086-0/09 PARING KNIFE / 9 CM
4506-0/20 CARVING KNIFE / 20 CM
4596-0/20 COOK'S KNIFE / 20 CM



Classic

STEAK KNIFE SET / WITH 4 CLASSIC KNIVES

9731 / 4002293273104

CONTENT

4068 STEAK KNIFE / 12 CM



STEAK KNIFE SET / WITH 6 CLASSIC KNIVES

9730 / 4002293273005

CONTENT

4068 STEAK KNIFE / 12 CM



Classic

KNIFE SET / WITH 3 CLASSIC KNIVES

9608 / 4002293960807

CONTENT

- 4066/09 PARING KNIFE / 9 CM
- 4522/16 SCHINKENMESSER / 16 CM
- 4582/20 COOK'S KNIFE / 20 CM



KNIFE SET / WITH 3 CLASSIC KNIVES

9660 / 4002293966007

CONTENT

- 4066/09 PARING KNIFE / 9 CM
- 4149 BREAD KNIFE / 20 CM
- 4582/20 COOK'S KNIFE / 20 CM



KNIFE SET / WITH 2 CLASSIC KNIVES

9755 / 4002293975504

CONTENT

- 4066/09 PARING KNIFE / 9 CM
- 4582/20 COOK'S KNIFE / 20 CM



KNIFE SET / WITH 2 CLASSIC KNIVES

9280 / 4002293928005

CONTENT

- 4000 PARING KNIFE / 8 CM
- 4183 SANTOKU / 17 CM



CARVING SET / WITH 2 CLASSIC PIECES

9740 / 4002293974002

CONTENT

- 4522/20 SCHINKENMESSER / 20 CM
- 4410/16 FLEISCHGABEL / 16 CM



Classic

KNIFE SET / WITH 4 PIECES

9750 / 4002293975009

CONTENT

- 4066/10 PARING KNIFE / 10 CM
- 4522/23 CARVING KNIFE / 23 CM
- 4582/20 COOK'S KNIFE / 20 CM
- 4460/23 SHARPENING STEEL / 23 CM



KNIFE SET / WITH 5 PIECES

9746 / 4002293974606

CONTENT

- 4066/10 PARING KNIFE / 10 CM
- 4149 BREAD KNIFE / 20 CM
- 4522/23 CARVING KNIFE / 23 CM
- 4582/20 COOK'S KNIFE / 20 CM
- 4460/23 SHARPENING STEEL / 23 CM



KNIFE SET / WITH 6 PIECES

9751 / 4002293975108

CONTENT

- 4066/10 PARING KNIFE / 10 CM
- 4602 BONING KNIFE / 14 CM
- 4149 BREAD KNIFE / 20 CM
- 4522/23 CARVING KNIFE / 23 CM
- 4582/20 COOK'S KNIFE / 20 CM
- 4460/23 SHARPENING STEEL / 23 CM



Classic

KNIFE SET / WITH 3 PIECES

9285 / 4002293928500

CONTENT

- 4582/20 COOK'S KNIFE / 20 CM
- 4686/18 CHINESE CHEF'S KNIFE / 18 CM
- 5558 KITCHEN SHEARS



TRAVELER SET / WITH 6 PIECES

9789 / 4002293978901

CONTENT

- 4066/09 PARING KNIFE / 9 CM
- 4110 SAUSAGE KNIFE / 14 CM
- 4582/16 COOK'S KNIFE / 16 CM
- 5558 KITCHEN SHEARS
- 4342 KNIFE SHARPENER
- 6930 WAITER'S KNIFE
- 7375 COOK'S CASE



Grand Prix II

STEAK KNIFE SET / WITH 4 GRAND PRIX II KNIVES

9625 / 4002293962504

CONTENT

- 4048 STEAK KNIFE / 12 CM



Grand Prix II

KNIFE SET / WITH 3 GRAND PRIX II KNIVES

9605 / 4002293260500

CONTENT

- 4040/09 PARING KNIFE / 9 CM
- 4525/16 UTILITY KNIFE / 16 CM
- 4585/20 COOK'S KNIFE / 20 CM



KNIFE SET / WITH 2 GRAND PRIX II KNIVES

9655 / 4002293965505

CONTENT

- 4040/09 PARING KNIFE / 9 CM
- 4585/20 COOK'S KNIFE / 20 CM



KNIFE SET / WITH 2 GRAND PRIX II KNIVES

9275 / 4002293927503

CONTENT

- 4015 PARING KNIFE / 8 CM
- 4175 SANTOKU / 17 CM



CARVING SET / WITH 2 GRAND PRIX II PIECES

9645 / 4002293964508

CONTENT

- 4525/20 CARVING KNIFE / 20 CM
- 4417 MEAT FORK / 16 CM



Gourmet

STEAK KNIFE SET / WITH 4 GOURMET KNIVES

9729 / 4002293972909

CONTENT

4050 STEAK KNIFE / 12 CM



STEAK KNIFE SET / WITH 6 GOURMET KNIVES

9728 / 4002293272800

CONTENT

4050 STEAK KNIFE / 12 CM



KNIFE SET / WITH 3 GOURMET KNIVES

9675 / 4002293267509

CONTENT

4045 UTILITY KNIFE / 12 CM
4114/16 UTILITY KNIFE / 16 CM
4562/20 COOK'S KNIFE / 20 CM



GEMÜSEKNIFE SET / WITH 3 GOURMET KNIVES

9727 / 4002293972701

CONTENT

4034 PEELING KNIFE / 6 CM
4042 PARING KNIFE / 8 CM
4010/08 PARING KNIFE / 8 CM



Gourmet

KNIFE SET / WITH 2 GOURMET KNIVES

9281 / 4002293928104

CONTENT

4010/09 PARING KNIFE / 9 CM
4585/20 SANTOKU / 17 CM



KNIFE SET / WITH 2 KNIVES

9261 / 4002293926100

CONTENT

4188 SANTOKU
4691/18 CHINESE CHEF'S KNIFE / 18 CM



CARVING SET / WITH 2 GOURMET PIECES

9704 / 4002293970400

CONTENT

4114/20 SLICER / 20 CM
4400/16 MEAT FORK / 16 CM



KNIFE SET / WITH 3 PIECES

8010 / 4002293801001

CONTENT

4562/20 COOK'S KNIFE / 20 CM
4691/18 CHINESE CHEF'S KNIFE / 18 CM
5558 KITCHEN SHEARS



Gourmet

KNIFE SET / WITH 3 PIECES

9288 / 4002293928807

CONTENT

- 4186 SANTOKU / 17 CM
- 4691/18 CHINESE CHEF'S KNIFE / 18 CM
- 5558 KITCHEN SHEARS



TRAVELER SET / WITH 6 PIECES

9789-1 / 4002293978918

CONTENT

- 4060/10 PARING KNIFE / 10 CM
- 4107 SAUSAGE KNIFE / 14 CM
- 4562/16 COOK'S KNIFE / 16 CM
- 5558 KITCHEN SHEARS
- 4342 KNIFE SHARPENER
- 6930 WAITER'S KNIFE
- 7375 COOK'S CASE



Silverpoint

STEAK KNIFE SET / WITH 4 SILVERPOINT KNIVES

9634 / 4002293963402

CONTENT

- 4041 STEAK KNIFE / 13 CM



KNIFE SET / WITH 3 SILVERPOINT KNIVES

9815 / 4002293981505

CONTENT

- 4051 UTILITY KNIFE / 12 CM
- 4510/20 SLICER / 20 CM
- 4561/18 COOK'S KNIFE / 18 CM



KNIFE SET / WITH 3 SILVERPOINT KNIVES

9814 / 4002293981406

CONTENT

- 4051 UTILITY KNIFE / 12 CM
- 4141 BREAD KNIFE / 20 CM
- 4561/18 COOK'S KNIFE / 18 CM



PARING KNIFE SET / WITH 3 SILVERPOINT KNIVES

9352 / 4002293935201

CONTENT

- 4033 PEELING KNIFE / 6 CM
- 4043 PARING KNIFE / 8 CM
- 4013 PARING KNIFE / 8 CM



Silverpoint

KNIFE SET / WITH 2 SILVERPOINT KNIVES

9279 / 4002293927909

CONTENT

4013 PARING KNIFE / 8 CM

4180 SANTOKU / 17 CM



CARVING SET / WITH 2 SILVERPOINT PIECES

9813 / 4002293981307

CONTENT

4510/20 SLICER / 20 CM

4407 MEAT FORK / 16 CM



KNIFE SET / WITH 2 PIECES

9811 / 4002293981109

CONTENT

4692/18 CHINESE CHEF'S KNIFE / 18 CM

4347 KNIFE SHARPENER



KNIFE SET / WITH 2 KNIVES

9284 / 4002293928401

CONTENT

4680/16 CLEAVER / 16 CM

4691/18 CHINESE CHEF'S KNIFE / 18 CM



KNIFE SET / WITH 2 PIECES

9282 / 4002293928203

CONTENT

4691/18 CHINESE CHEF'S KNIFE / 18 CM

4347 KNIFE SHARPENER



Modern design sculpture in the kitchen

PROFESSIONAL KNIFE STORAGE - FOR OPTIMAL BLADE PROTECTION

Knives are the most important tools in the kitchen and every hobby and pro cook knows: Only a sharp knife is a good knife.

To enjoy a smooth cutting experience for longer, they should therefore be reliably protected from scratches and damage. We offer a large selection of safe storage options for this: Whether it is a knife block, magnetic holder, in-drawer knife organizer, blade guard or Traveller Set – with the right storage, kitchen knives remain sharp for longer.

Our tip: With our ultra-modern designer knife blocks, every kitchen is not only upgraded with a genuine eye-catcher, the knives are also always close to hand.

Epicure





MAGNETIC BLOCK / WITH 6 EPICURE KNIVES

WEIGHT: 5,54 KG / MATERIAL: THERMO BEECH WOOD, STAINLESS STEEL / WOODEN PART: W 36 x H 24 x D 4 CM / KNIFE BLOCK WITH BASE: W 36,5 x H 42 x D 21,5 CM

9884-2 / 4002293988429

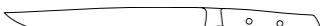

CONTENT

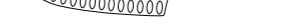
- | | | |
|---|---------|-----------------------|
|  | 3966/09 | PARING KNIFE / 9 CM |
|  | 3911 | SAUSAGE KNIFE / 14 CM |
|  | 3922/23 | CARVING KNIFE / 23 CM |
|  | 3950/23 | BREAD KNIFE / 23 CM |
|  | 3983 | SANTOKU / 17 CM |
|  | 3982/20 | COOK'S KNIFE / 20 CM |
| | 7231 | MAGNETIC KNIFE BLOCK |





Epicure

KNIFE BLOCK / WITH 6 EPICURE KNIVES

WEIGHT: 3,12 KG / MATERIAL: THERMO BEECH WOOD, STAINLESS STEEL / W 33,4 CM x H 33,8 CM x D 11,5 CM

9854 / 4002293985404

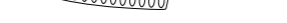

CONTENT	
	3966/09 PARING KNIFE / 9 CM
	3911 SAUSAGE KNIFE / 14 CM
	3922/23 CARVING KNIFE / 23 CM
	3950/23 BREAD KNIFE / 23 CM
	3983 SANTOKU / 17 CM
	3982/20 COOK'S KNIFE / 20 CM
	7260 KNIFE BLOCK



Crafter

KNIFE BLOCK / WITH 2 CRAFTER KNIVES

WEIGHT: 1,88 KG / MATERIAL: SMOKED OAK, OAK, MAPLE, THERMO BEECH WOOD / W 14 CM x H 36,5 CM x D 11 CM

9845 / 4002293984506

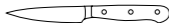





CONTENT	
	3765/09 PARING KNIFE / 9 CM
	3781/20 COOK'S KNIFE / 20 CM
	7230 KNIFE BLOCK

KNIFE BLOCK / WITH 6 EPICURE KNIVES

WEIGHT: 3,15 KG / MATERIAL: ASH WOOD, CRÈME, STAINLESS STEEL / W 33,4 CM x H 33,8 CM x D 11,5 CM

9856 / 4002293985602



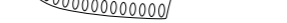



CONTENT	
	3966/09 PARING KNIFE / 9 CM
	3911 SAUSAGE KNIFE / 14 CM
	3922/23 CARVING KNIFE / 23 CM
	3950/23 BREAD KNIFE / 23 CM
	3983 SANTOKU / 17 CM
	3982/20 COOK'S KNIFE / 20 CM
	7266 KNIFE BLOCK

KNIFE BLOCK / WITH 6 CRAFTER KNIVES

WEIGHT: 2,43 KG / MATERIAL: SMOKED OAK, OAK, MAPLE, THERMO BEECH WOOD / W 14 CM x H 36,5 CM x D 11 CM

9834 / 4002293983400



CONTENT	
	3765/09 PARING KNIFE / 9 CM
	3710 SAUSAGE KNIFE / 14 CM
	3723/20 UTILITY KNIFE / 16 CM
	3752/23 BREAD KNIFE / 23 CM
	3783/17 SANTOKU / 17 CM
	3781/20 COOK'S KNIFE / 20 CM
	7230 KNIFE BLOCK

Urban Farmer

TOOL BASKET / WITH 4 URBAN FARMER KNIVES





WEIGHT: 3,14 KG / MATERIAL: BEECH WOOD, STAINLESS STEEL / W 37,5 x H 13,5 x D 17,5 CM

9480 / 4002293948003

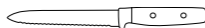

NEW

CONTENT

-  **3400/08** PRUNING KNIFE / 8 CM
-  **3466/10** PARING KNIFE / 10 CM
-  **3410/14** SERRATED UTILITY KNIFE / 14 CM
-  **3483/17** SANTOKU / 17 CM
- 7410** TOOL BASKET

Ikon







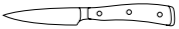

KNIFE BLOCK / WITH 9 IKON PIECES

WEIGHT: 4,33 KG / MATERIAL: ASH WOOD, BROWN / W 33,4 CM x H 32,2 CM x D 14,5 CM

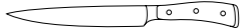
9865 / 4002293986500



CONTENT

-  **4920** PEELING KNIFE / 7 CM
-  **4986/09** PARING KNIFE / 9 CM
-  **4926** SAUSAGE KNIFE / 14 CM
-  **4906/16** UTILITY KNIFE / 16 CM
-  **4966/23** BREAD KNIFE / 23 CM
-  **4976** SANTOKU / 17 CM
-  **4996/20** COOK'S KNIFE / 20 CM
-  **4914/16** MEAT FORK / 16 CM
-  **4968** SHARPENING STEEL / 26 CM
- 7255** KNIFE BLOCK

Ikon

KNIFE BLOCK / WITH 6 IKON KNIVES

WEIGHT: 3,31 KG / MATERIAL: ASH WOOD, BROWN / W 33,4 CM x H 33,8 CM x D 11,5 CM

9866 / 4002293986609



CONTENT

-  **4986/09** PARING KNIFE / 9 CM
-  **4926** SAUSAGE KNIFE / 14 CM
-  **4906/16** UTILITY KNIFE / 16 CM
-  **4966/23** BREAD KNIFE / 23 CM
-  **4976** SANTOKU / 17 CM
-  **4996/20** COOK'S KNIFE / 20 CM
- 7251** KNIFE BLOCK

Classic Ikon

KNIFE BLOCK / WITH 6 CLASSIC IKON KNIVES

WEIGHT: 3,31 KG / MATERIAL: ASH WOOD, BLACK / W 33,4 CM x H 33,8 CM x D 11,5 CM

9876 / 4002293987606



CONTENT

-  **4086/09** PARING KNIFE / 9 CM
-  **4126** SAUSAGE KNIFE / 14 CM
-  **4506/16** UTILITY KNIFE / 16 CM
-  **4163/23** BREAD KNIFE / 23 CM
-  **4176** SANTOKU / 17 CM
-  **4596/20** COOK'S KNIFE / 20 CM
- 7250** KNIFE BLOCK





Classic Ikon

KNIFE BLOCK / WITH 9 CLASSIC IKON PIECES

WEIGHT: 4,33 KG / MATERIAL: ASH WOOD, BLACK / W 33,4 CM x H 32,2 CM x D 14,5 CM

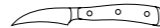
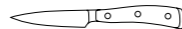
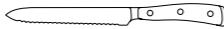
9873 / 4002293987309

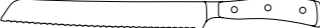
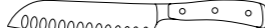

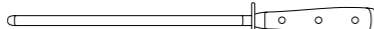
CONTENT		
	4020	PEELING KNIFE / 7 CM
	4086/09	PARING KNIFE / 9 CM
	4126	SAUSAGE KNIFE / 14 CM
	4506/16	UTILITY KNIFE / 16 CM
	4163/23	BREAD KNIFE / 23 CM
	4176	SANTOKU / 17 CM
	4596/20	COOK'S KNIFE / 20 CM
	4414/16	MEAT FORK / 16 CM
	4468	SHARPENING STEEL / 26 CM
	7253	KNIFE BLOCK





Classic Ikon

KNIFE BLOCK / WITH 7 PIECES

WEIGHT: 2,42 KG / MATERIAL: ASH WOOD, BLACK / W 33 CM x H 30 CM x D 8,5 CM

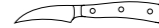
9878 / 4002293987804





CONTENT		
	4020	PEELING KNIFE / 7 CM
	4086/09	PARING KNIFE / 9 CM
	4506/16	UTILITY KNIFE / 16 CM
	4166/20	BREAD KNIFE / 20 CM
	4596/20	COOK'S KNIFE / 20 CM
	4465	SHARPENING STEEL / 23 CM
	5558	KITCHEN SHEARS
	7238	KNIFE BLOCK

KNIFE BLOCK / WITH 7 PIECES

WEIGHT: 2,63 KG / MATERIAL: BEECH WOOD / W 32,7 CM x H 28,9 CM x D 8,6 CM

9875 / 4002293987507

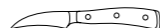
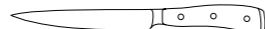







CONTENT		
	4020	PEELING KNIFE / 7 CM
	4086/09	PARING KNIFE / 9 CM
	4506/16	UTILITY KNIFE / 16 CM
	4166/20	BREAD KNIFE / 20 CM
	4596/20	COOK'S KNIFE / 20 CM
	4465	SHARPENING STEEL / 23 CM
	5558	KITCHEN SHEARS
	7235	KNIFE BLOCK

KNIFE BLOCK / WITH 8 PIECES

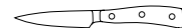
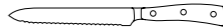
WEIGHT: 3,95 KG / MATERIAL: ASH WOOD, BLACK / W 30,7 CM x H 32,1 CM x D 15,5 CM

9880 / 4002293988009

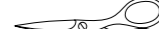

CONTENT		
	4086/09	PARING KNIFE / 7 CM
	4126	SAUSAGE KNIFE / 14 CM
	4506/16	UTILITY KNIFE / 16 CM
	4166/23	BREAD KNIFE / 23 CM
	4176	SANTOKU / 17 CM
	4596/20	COOK'S KNIFE / 20 CM
	4468	SHARPENING STEEL / 26 CM
	5553	KITCHEN SHEARS
	7264	KNIFE BLOCK







Classic Ikon

KNIFE BLOCK / WITH 8 PIECES

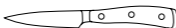
WEIGHT: 3,87 KG / MATERIAL: THERMO BEECH WOOD / W 31,8 CM x H 30,9 CM x D 15,6 CM

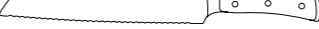
9882 / 4002293988207









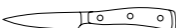

CONTENT	
	4086/09 PARING KNIFE / 9 CM
	4126 SAUSAGE KNIFE / 14 CM
	4506/16 UTILITY KNIFE / 16 CM
	4166/23 BREAD KNIFE / 23 CM
	4176 SANTOKU / 17 CM
	4596/20 COOK'S KNIFE / 20 CM
	4468 SHARPENING STEEL / 26 CM
	5553 KITCHEN SHEARS
	7265 KNIFE BLOCK

KNIFE BLOCK / WITH 8 PIECES

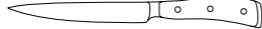
WEIGHT: 3,87 KG / MATERIAL: THERMO BEECH WOOD / W 31,8 CM x H 30,9 CM x D 15,6 CM

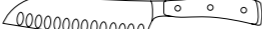
9879 / 4002293987903

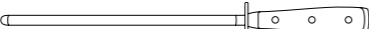

CONTENT	
	4086-0/09 PARING KNIFE / 9 CM
	4126-0 SAUSAGE KNIFE / 14 CM
	4506-0/16 UTILITY KNIFE / 16 CM
	4166-0/23 BREAD KNIFE / 23 CM
	4176-0 SANTOKU / 17 CM
	4596-0/20 COOK'S KNIFE / 20 CM
	4468-0 SHARPENING STEEL / 26 CM
	5553 KITCHEN SHEARS
	7265 KNIFE BLOCK





Classic Ikon

KNIFE BLOCK / WITH 6 CLASSIC IKON KNIVES

WEIGHT: 3,17 KG / MATERIAL: ASH WOOD, CRÈME / W 33,4 CM x H 33,8 CM x D 11,5 CM

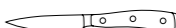
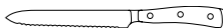
9877 / 4002293987705

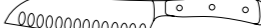







CONTENT	
	4086-0/09 PARING KNIFE / 9 CM
	4126-0 SAUSAGE KNIFE / 14 CM
	4506-0/16 UTILITY KNIFE / 16 CM
	4166-0/23 BREAD KNIFE / 23 CM
	4176-0 SANTOKU / 17 CM
	4596-0/20 COOK'S KNIFE / 20 CM
	7252 KNIFE BLOCK

KNIFE BLOCK / WITH 9 CLASSIC IKON PIECES

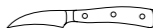
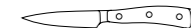
WEIGHT: 4,35 KG / MATERIAL: ASH WOOD, CRÈME / W 33,9 CM x H 32,9 CM x D 14,4 CM

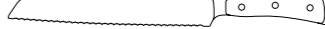
9874 / 4002293987408



CONTENT	
	4020-0 PEELING KNIFE / 7 CM
	4086-0/09 PARING KNIFE / 9 CM
	4126-0 SAUSAGE KNIFE / 14 CM
	4506-0/16 UTILITY KNIFE / 16 CM
	4166-0/23 BREAD KNIFE / 23 CM
	4176-0 SANTOKU / 17 CM
	4596-0/20 COOK'S KNIFE / 20 CM
	4414-0/16 MEAT FORK / 16 CM
	4468-0 SHARPENING STEEL / 26 CM
	7254 KNIFE BLOCK







Classic

KNIFE BLOCK / WITH 5 PIECES

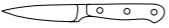
WEIGHT: 2,1 KG / MATERIAL: BEECH WOOD / W 32,3 CM x H 31,3 CM x D 11,2 CM

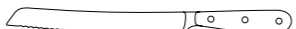
9832 / 4002293983202

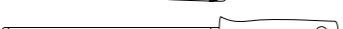

CONTENT	
	4066/09 PARING KNIFE / 9 CM
	4522/20 CARVING KNIFE / 20 CM
	4149 BREAD KNIFE / 20 CM
	4582/20 COOK'S KNIFE / 20 CM
	4465/23 SHARPENING STEEL / 23 CM
	7242 KNIFE BLOCK







Classic

KNIFE BLOCK / WITH 7 PIECES

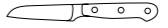
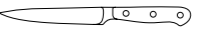
WEIGHT: 2,46 KG / MATERIAL: BEECH WOOD / W 32,8 CM x H 29,5 CM x D 8,6 CM

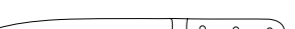
9835 / 4002293983509









CONTENT	
	4000 PARING KNIFE / 8 CM
	4066/12 UTILITY KNIFE / 12 CM
	4522/20 CARVING KNIFE / 20 CM
	4149 BREAD KNIFE / 20 CM
	4582/20 COOK'S KNIFE / 20 CM
	4465/23 SHARPENING STEEL / 23 CM
	5558 KITCHEN SHEARS
	7235 KNIFE BLOCK

KNIFE BLOCK / WITH 5 PIECES

WEIGHT: 2,9 KG / MATERIAL: ASH WOOD, BLACK / W 35,1 CM x H 31,5 CM x D 8,7 CM

9838-8 / 4002293983882

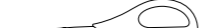







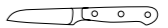

CONTENT	
	4522/16 UTILITY KNIFE / 16 CM
	4680/18 CLEAVER / 18 CM
	4686/18 CHINESE CHEF'S KNIFE / 18 CM
	4465/23 SHARPENING STEEL / 23 CM
	5558 KITCHEN SHEARS
	7238-11 KNIFE BLOCK

KNIFE BLOCK / WITH 7 PIECES

WEIGHT: 2,29 KG / MATERIAL: ASH WOOD, BLACK / W 32,8 CM x H 29,5 CM x D 8,6 CM

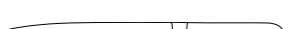
9837 / 4002293983707



CONTENT	
	4000 PARING KNIFE / 8 CM
	4066/12 UTILITY KNIFE / 12 CM
	4522/20 CARVING KNIFE / 20 CM
	4149 BREAD KNIFE / 20 CM
	4582/20 COOK'S KNIFE / 20 CM
	4465/23 SHARPENING STEEL / 23 CM
	5558 KITCHEN SHEARS
	7238 KNIFE BLOCK

Classic

KNIFE BLOCKS / WITH 9 PIECES

9842 / 4002293984209

WEIGHT: 3,48 KG / MATERIAL: BEECH WOOD
W 32 CM x H 30,9 CM x D 11,2 CM

7242 / KNIFE BLOCK



CONTENT



9843 / 4002293984308

WEIGHT: 3,24 KG / MATERIAL: ASH WOOD, BROWN
W 32 CM x H 30,9 CM x D 11,2 CM

7243 / KNIFE BLOCK



9844 / 4002293984407

WEIGHT: 3,24 KG / MATERIAL: ASH WOOD, BLACK
W 32 CM x H 30,9 CM x D 11,2 CM

7244 / KNIFE BLOCK



Classic

KNIFE BLOCKS / WITH 12 PIECES

9846 / 4002293984605

WEIGHT: 5,56 KG / MATERIAL: BEECH WOOD
W 36 CM x H 33 CM x D 14 CM

7246 / KNIFE BLOCK



CONTENT

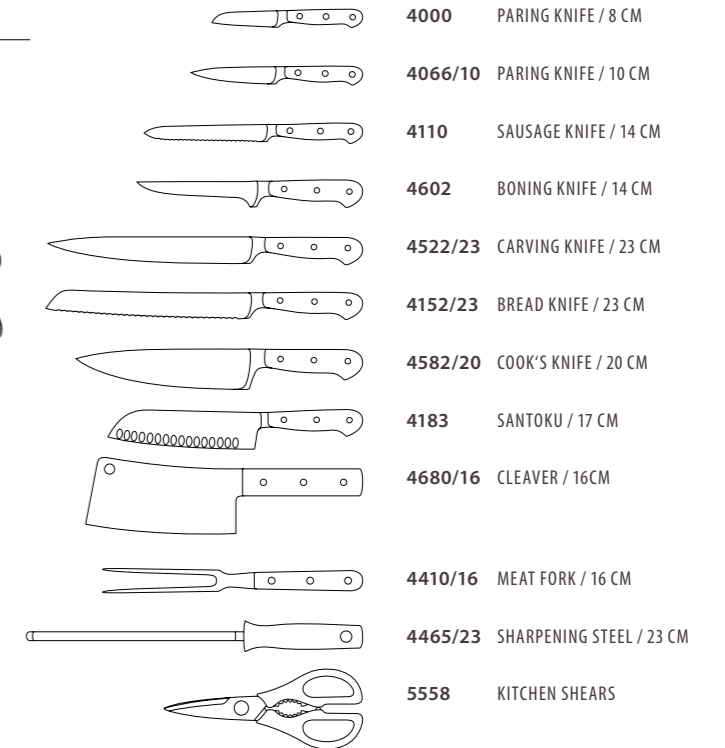

9847 / 4002293984704

WEIGHT: 5,51 KG / MATERIAL: ASH WOOD, BROWN
W 36 CM x H 33 CM x D 14 CM

7247 / KNIFE BLOCK



9848 / 4002293984803

WEIGHT: 5,51 KG / MATERIAL: ASH WOOD, BLACK
W 36 CM x H 33 CM x D 14 CM

7248 / KNIFE BLOCK







Grand Prix II

KNIFE BLOCK / WITH 7 PIECES

WEIGHT: 2,46 KG / MATERIAL: BEECH WOOD / W 33,6 CM x H 29,7 CM x D 8,5 CM

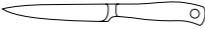
9851 / 4002293985107

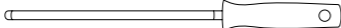
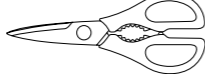

CONTENT	
	4015 PARING KNIFE / 8 CM
	4040/12 UTILITY KNIFE / 12 CM
	4525/20 CARVING KNIFE / 20 CM
	4165 BREAD KNIFE / 23 CM
	4585/20 COOK'S KNIFE / 20 CM
	4465/23 SHARPENING STEEL / 23 CM
	5558 KITCHEN SHEARS
	7235 KNIFE BLOCK



Gourmet

KNIFE BLOCK / WITH 6 PIECES

WEIGHT: 2,15 KG / MATERIAL: BEECH WOOD / W 32,8 CM x H 29,5 CM x D 8,6 CM

9831-2 / 4002293983127

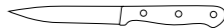
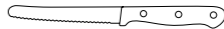
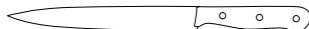

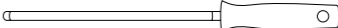
CONTENT	
	4045 PARING KNIFE / 12 CM
	4101 BRUNCH KNIFE / 12 CM
	4114/20 SLICER / 20 CM
	4143 BREAD KNIFE / 20 CM
	4562/20 COOK'S KNIFE / 20 CM
	4465/23 SHARPENING STEEL / 23 CM
	7235 KNIFE BLOCK



Gourmet

KNIFE BLOCK / WITH 5 PIECES

WEIGHT: 1,52 KG / MATERIAL: BEECH WOOD / W 28,6 CM x H 27,3 CM x D 8 CM

9867 / 4002293986715

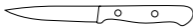



CONTENT	
	4034 PEELING KNIFE / 6 CM
	4060 PARING KNIFE / 10 CM
	4143 BREAD KNIFE / 20 CM
	4562/18 COOK'S KNIFE / 18 CM
	4465/23 SHARPENING STEEL / 23 CM
	7245 KNIFE BLOCK

KNIFE BLOCK / WITH 5 PIECES

WEIGHT: 2,78 KG / MATERIAL: BEECH WOOD / W 35,8 CM x H 31,5 CM x D 8,8 CM

9835-8 / 4002293983585

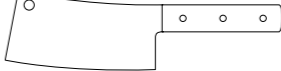

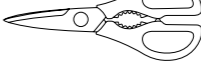
CONTENT	
	4114/16 UTILITY KNIFE / 16 CM
	4680/16 CLEAVER / 16 CM
	4688/20 CHINESE CHEF'S KNIFE / 20 CM
	4465/23 SHARPENING STEEL / 23 CM
	5558 KITCHEN SHEARS
	7235-11 KNIFE BLOCK





Silverpoint

KNIFE BLOCK / WITH 5 PIECES

WEIGHT: 1,47 KG / MATERIAL: BEECH WOOD / W 29,8 CM x H 26,8 CM x D 8 CM

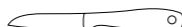
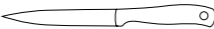
9829 / 4002293982908

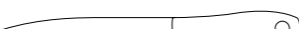





CONTENT	
	4013 PARING KNIFE / 8 CM
	4051 UTILITY KNIFE / 12 CM
	4141 BREAD KNIFE / 20 CM
	4561/18 COOK'S KNIFE / 18 CM
	4465/23 SHARPENING STEEL / 23 CM
	7245 KNIFE BLOCK

KNIFE BLOCK / WITH 7 PIECES

WEIGHT: 2,11 KG / MATERIAL: BEECH WOOD / W 33,9 CM x H 29,2 CM x D 8,5 CM

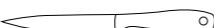
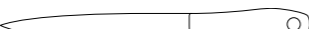
9864 / 4002293986401

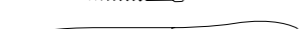

CONTENT	
	4013 PARING KNIFE / 8 CM
	4051 UTILITY KNIFE / 12 CM
	4510/20 SLICER / 20 CM
	4141 BREAD KNIFE / 20 CM
	4561/18 COOK'S KNIFE / 18 CM
	4465/23 SHARPENING STEEL / 23 CM
	5558 KITCHEN SHEARS
	7235 KNIFE BLOCK

Magnetic block

7231 / 4002293723105

WEIGHT: 4,45 KG / MATERIAL: THERMO BEECH WOOD, STAINLESS STEEL / WOODEN PART: W 36 x H 24 x D 4 CM / KNIFE BLOCK WITH BASE: W 36,5 x H 28 x D 15,5 CM



Knife block

7230 / 4002293723006

WEIGHT: 1,64 KG
MATERIAL: SMOKED OAK, OAK,
MAPLE, THERMO BEECH WOOD
W 14 CM x H 24 CM x D 11 CM



Tool basket

7410 / 4002293741000

WEIGHT: 2,67 KG
MATERIAL: BEECH WOOD, STAINLESS STEEL
W 37,5 CM x H 13,5 CM x D 17,5 CM



Knife blocks

7249 / 4002293724904

WEIGHT: 3,37 KG
 MATERIAL: THERMO BEECH WOOD
 W 23 CM x H 26 CM x D 9 CM
 MAGNETIC
 FOR WALL FIXING



7262 / 4002293726205

WEIGHT: 2,91 KG
 MATERIAL: THERMO BEECH WOOD
 W 15 CM x H 28,7 CM x D 15 CM



Knife blocks

7275-1 / 4002293727523

WEIGHT: 2,6 KG
 MATERIAL: BEECH WOOD,
 STAINLESS STEEL
 W 15,7 CM x H 25,3 CM x D 17,9 CM
 MAGNETIC



7277-1 / 4002293727714

WEIGHT: 2,6 KG
 MATERIAL: ASH WOOD, BLACK,
 STAINLESS STEEL
 W 15,7 CM x H 25,3 CM x D 17,9 CM
 MAGNETIC



7267 / 4002293726700

WEIGHT: 2,85 KG
 MATERIAL: THERMO BEECH WOOD,
 STAINLESS STEEL
 W 15,7 CM x H 25,3 CM x D 17,9 CM
 MAGNETIC



7258 / 4002293725802

WEIGHT: 3,32 KG
 MATERIAL: CONCRETE, THERMO BEECH WOOD
 W 12,6 CM x H 24,6 CM x D 12,6 CM

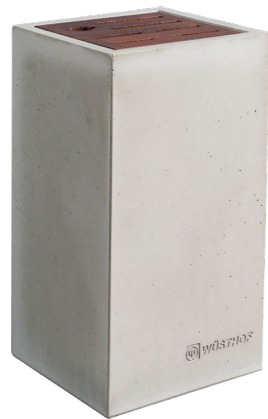

7260 / 4002293726014

WEIGHT: 2,1 KG
 MATERIAL: THERMO BEECH WOOD,
 STAINLESS STEEL
 W 24,3 CM x H 22,3 CM x D 12,7 CM



7266 / 4002293726601

WEIGHT: 2,1 KG
 MATERIAL: ASH WOOD, CRÈME,
 STAINLESS STEEL
 W 24,3 CM x H 22,3 CM x D 12,7 CM



7272-1 / 4002293727219

WEIGHT: 4,48 KG
 MATERIAL: BEECH WOOD
 W 20,6 CM x H 28,5 CM x D 11,5 CM



7278-1 / 4002293727813

WEIGHT: 4,48 KG
 MATERIAL: ASH WOOD, BLACK
 W 20,6 CM x H 28,5 CM x D 11,5 CM

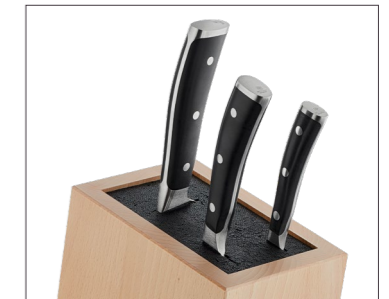

Knife blocks

7264 / 4002293726403

WEIGHT: 2,5 KG
MATERIAL: ASH WOOD, BLACK
W 25,5 CM x H 21,4 CM x D 15,6 CM



7265 / 4002293726502

WEIGHT: 2,5 KG
MATERIAL: THERMO BEECH WOOD
W 25,5 CM x H 21,4 CM x D 15,6 CM



7240 / 4002293724003

WEIGHT: 2,09 KG
MATERIAL: BEECH WOOD
W 27,4 CM x H 23,4 CM x D 10,5 CM



7239 / 4002293723907

WEIGHT: 1,28 KG
MATERIAL: BEECH WOOD
W 23 CM x H 20,5 CM x D 8,5 CM



7237 / 4002293723709

WEIGHT: 1,28 KG
MATERIAL: ASH WOOD, BLACK
W 23 CM x H 20,5 CM x D 8,5 CM



Knife blocks

7242 / 4002293724201

WEIGHT: 2,23 KG
MATERIAL: BEECH WOOD
W 26,2 CM x H 22,5 CM x D 11,2 CM



7244 / 4002293724409

WEIGHT: 2,23 KG
MATERIAL: ASH WOOD, BLACK
W 26,2 CM x H 22,5 CM x D 11,2 CM



7243 / 4002293724300

WEIGHT: 2,23 KG
MATERIAL: ASH WOOD, BROWN
W 26,2 CM x H 22,5 CM x D 11,2 CM



7246 / 4002293724607

WEIGHT: 3,24 KG
MATERIAL: BEECH WOOD
W 29 CM x H 25,3 CM x D 14 CM



7248 / 4002293724805

WEIGHT: 3,24 KG
MATERIAL: ASH WOOD, BLACK
W 29 CM x H 25,3 CM x D 14 CM



7247 / 4002293724706

WEIGHT: 3,24 KG
MATERIAL: ASH WOOD, BROWN
W 29 CM x H 25,3 CM x D 14 CM



Knife blocks

7252 / 4002293725208

WEIGHT: 2,34 KG
MATERIAL: ASH WOOD, CRÈME
W 28,3 CM x H 24 CM x D 11,7 CM



7250 / 4002293725000

WEIGHT: 2,34 KG
MATERIAL: ASH WOOD, BLACK
W 28,3 CM x H 24 CM x D 11,7 CM



7251 / 4002293725109

WEIGHT: 2,34 KG
MATERIAL: ASH WOOD, BROWN
W 28,3 CM x H 24 CM x D 11,7 CM



7254 / 4002293725406

WEIGHT: 2,8 KG
MATERIAL: ASH WOOD, CRÈME
W 28,4 CM x H 24,3 CM x D 14,6 CM



7253 / 4002293725307

WEIGHT: 2,8 KG
MATERIAL: ASH WOOD, BLACK
W 28,4 CM x H 24,3 CM x D 14,6 CM



7255 / 4002293725505

WEIGHT: 2,8 KG
MATERIAL: ASH WOOD, BROWN
W 28,4 CM x H 24,3 CM x D 14,6 CM



In-drawer knife organizer

Knives not included.

7270 / 4002293727004

WEIGHT: 750 G / MATERIAL: BEECH WOOD / L 42,6 CM x W 10 CM x H 4,4 CM / FOR 7 KNIVES



7271 / 4002293727103

WEIGHT: 1,49 KG / MATERIAL: BEECH WOOD / L 42,5 CM x W 20 CM x H 4,4 CM / FOR 15 KNIVES



7273 / 4002293727301

WEIGHT: 1,01 KG / MATERIAL: BEECH WOOD / L 43 CM x W 22,2 CM x H 4,4 CM / FOR 7 KNIVES



7279 / 4002293727905

WEIGHT: 1,26 KG / MATERIAL: SYNTHETIC MATERIAL, WHITE / L 43 CM x W 22,2 CM x H 4,4 CM / FOR 7 KNIVES



Magnetic holder

7221/30 / 4002293722115

WEIGHT: 780 G / MATERIAL: ACACIA / L 30 CM x W 2 CM x H 6,3 CM

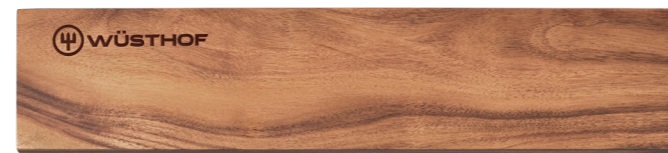

7221/50 / 4002293572215

WEIGHT: 1,4 KG / MATERIAL: ACACIA / L 50 CM x W 2 CM x H 6,3 CM

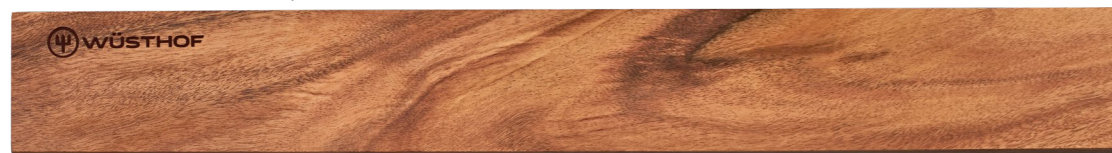

7222/30 / 4002293372228

WEIGHT: 780 G / MATERIAL: WALNUT / L 30 CM x W 2 CM x H 6,3 CM

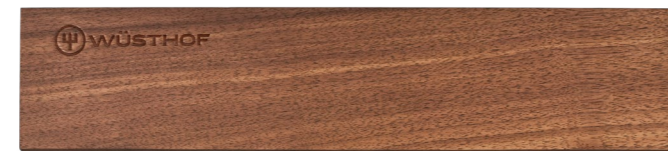

7222/50 / 4002293572222

WEIGHT: 1,4 KG / MATERIAL: WALNUT / L 50 CM x W 2 CM x H 6,3 CM

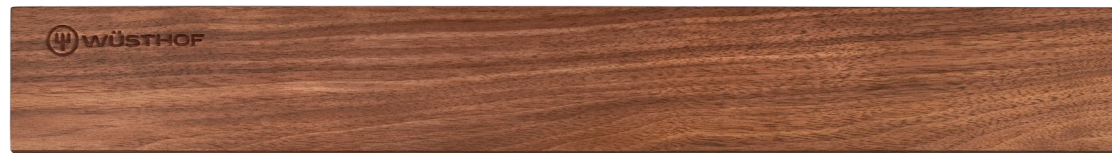

7224/40 / 4002293722405

WEIGHT: 800 G / MATERIAL: THERMO BEECH WOOD / L 40 CM x W 3,5 CM x H 6,3 CM



7223/30 / 4002293722313

WEIGHT: 336 G / MATERIAL: RUBBERWOOD / L 30,1 CM x W 2 CM x H 4,5 CM



7223/45 / 4002293722320

WEIGHT: 516 G / MATERIAL: RUBBERWOOD / L 45,2 CM x W 2 CM x H 4 CM



Magnetic holder

7225/30 / 4002293722511

WEIGHT: 272 G / MATERIAL: SYNTHETIC MATERIAL / L 31,2 CM x W 2,5 CM x H 4,3 CM



7225/45 / 4002293722528

WEIGHT: 397 G / MATERIAL: SYNTHETIC MATERIAL / L 46,2 CM x W 2,6 CM x H 4,5 CM



7226/35 / 4002293722610

WEIGHT: 440 G / MATERIAL: SYNTHETIC MATERIAL / L 35 CM x W 2,6 CM x H 4 CM



7226/50 / 4002293722627

WEIGHT: 636 G / MATERIAL: SYNTHETIC MATERIAL / L 50 CM x W 2,4 CM x H 4 CM



7227/30 / 4002293722702

WEIGHT: 269 G / MATERIAL: ALUMINUM / L 31 CM x W 2,8 CM x H 3,9 CM



7227/45 / 4002293722719

WEIGHT: 386 G / MATERIAL: ALUMINUM / L 46 CM x W 2,6 CM x H 4 CM



7228/35 / 4002293722818

WEIGHT: 476 G / MATERIAL: ALUMINUM / L 35 CM x W 2,6 CM x H 4 CM



7228/50 / 4002293722825

WEIGHT: 720 G / MATERIAL: ALUMINUM / L 50,2 CM x W 2,3 CM x H 4,3 CM



Chef's attaché cases

9774-1 / 4002293977416 / with 25 pieces

WEIGHT: 7,17 KG / MATERIAL: ALUMINUM, SYNTHETIC MATERIAL
W 52 CM x H 11,8 CM x D 38,7 CM

CONTENT

7384	CHEF'S ATTACHÉ CASE	4474/32	SHARPENING STEEL / 32 CM
4680/18	CLEAVER / 18 CM	4532	SUPER SLICER / 26 CM
4584/26	COOK'S KNIFE / 26 CM	4543	SALMON SLICER / 32 CM
4582/20	COOK'S KNIFE / 20 CM	4430/25	PALETTE / 25 CM
4522/23	CARVING KNIFE / 23 CM	4410/18	MEAT FORK / 18 CM
4150	BREAD KNIFE / 23 CM	4204	DECORATING KNIFE / 10 CM
4550/18	FILLET KNIFE / 18 CM	4066/10	PARING KNIFE / 10 CM
4602	BONING KNIFE / 14 CM	4002	PARING KNIFE / 7 CM
3066	CHANNEL KNIFE	4062	PEELING KNIFE / 7 CM
3086	LEMON ZESTER	5880	FISHBONE PLIERS / 18 CM
4246	APPLE CORER	5550-1	KITCHEN SHEARS
4241	MELON BALLER	4385	TRUSSING NEEDLE / 16 CM
		4382	LARDING NEEDLE / 18 CM
		4380	LARDING NEEDLE / 20 CM



7384 / 4002293738406 / empty / with 2 inlays

WEIGHT: 4 KG / MATERIAL: ALUMINUM, SYNTHETIC MATERIAL
W 52 CM x H 11,8 CM x D 38,7 CM



Chef's attaché cases

9771 / 4002293977102 / with 18 pieces

WEIGHT: 4,34 KG / MATERIAL: ALUMINUM, SYNTHETIC MATERIAL
W 44,9 CM x H 10,9 CM x D 32 CM

CONTENT

7388	CHEF'S ATTACHÉ CASE	4473	SHARPENING STEEL / 26 CM
4585/20	COOK'S KNIFE / 20 CM	4544	SALMON SLICER / 29 CM
4525/23	CARVING KNIFE / 23 CM	4501/26	CONFECTIONER'S KNIFE / 26 CM
4551	FILLET KNIFE / 16 CM	4420/25	PALETTE / 25 CM
4385	TRUSSING NEEDLE / 16 CM	4605	BONING KNIFE / 14 CM
4206	DECORATING KNIFE / 9 CM	4407	KITCHEN FORK / 16 CM
4023	PARING KNIFE / 8 CM	4380	LARDING NEEDLE / 20 CM
4033	PEELING KNIFE / 6 CM		
4245	APPLE CORER		
4241	MELON BALLER		
3066	CHANNEL KNIFE		
3086	LEMON ZESTER		



9778 / 4002293977805 / with 18 pieces

WEIGHT: 4,56 KG / MATERIAL: ALUMINUM, SYNTHETIC MATERIAL
W 44,9 CM x H 10,9 CM x D 32 CM

CONTENT

7388	CHEF'S ATTACHÉ CASE	4473	SHARPENING STEEL / 26 CM
4582/20	COOK'S KNIFE / 20 CM	4540	SALMON SLICER / 29 CM
4522/23	CARVING KNIFE / 23 CM	4517	CONFECTIONER'S KNIFE / 26 CM
4518/16	FILLET KNIFE / 16 CM	4430/25	PALETTE / 25 CM
4400/16	KITCHEN FORK / 16 CM	4606/14	BONING KNIFE / 14 CM
4204	DECORATING KNIFE / 10 CM	4385	TRUSSING NEEDLE / 16 CM
4060	PARING KNIFE / 10 CM	4380	LARDING NEEDLE / 20 CM
4034	PEELING KNIFE / 6 CM		
4245	APPLE CORER		
4241	MELON BALLER		
3066	CHANNEL KNIFE		
3086	LEMON ZESTER		

7388 / 4002293738802 / empty / with 2 inlays

WEIGHT: 2,88 KG



Cook's cases

GARNISHING SET / WITH 6 PIECES

WEIGHT: 270 G / MATERIAL: ARTIFICIAL LEATHER, BINDING MADE FROM PVC STRIP / ROLLED UP: L 23,6 CM x W 8,7 CM / UNFOLDED: L 28,7 CM x W 23,4 CM

9888 / 4002293988801

CONTENT

4246 APPLE CORER
4072 PEELER
4240/2.5 MELON BALLER
3066 CHANNEL KNIFE
3086 LEMON ZESTER
4033 PEELING KNIFE / 6 CM
7373 GADET CASE



COOK'S CASE / WITH 6 PIECES

WEIGHT: 920 G / MATERIAL: ARTIFICIAL LEATHER / ROLLED UP: L 42,5 CM x W 13 CM / UNFOLDED: L 42,5 CM x W 41,5 CM

9783 / 4002293978307

CONTENT

4463/23 SHARPENING STEEL / 23 CM
4585/20 COOK'S KNIFE / 20 CM
4501/23 CONFECTIONER'S KNIFE / 23 CM
4551 FILLET KNIFE / 16 CM
4051 UTILITY KNIFE / 12 CM
4033 PEELING KNIFE / 6 CM
7370 KNIFE ROLL



Cook's cases

COOK'S STARTER SET / WITH 5 PIECES

WEIGHT: 1 KG / MATERIAL: ARTIFICIAL LEATHER / ROLLED UP: L 42,5 CM x W 13 CM / UNFOLDED: L 42,5 CM x W 41,5 CM

9780 / 4002293978000

CONTENT

4473 SHARPENING STEEL / 26 CM
4582/23 COOK'S KNIFE / 23 CM
4606/14 BONING KNIFE / 14 CM
4400/16 KITCHEN FORK / 16 CM
4066/10 PARING KNIFE / 10 CM
7370 KNIFE ROLL



COOK'S STARTER SET / WITH 5 PIECES

WEIGHT: 1,05 KG / MATERIAL: ARTIFICIAL LEATHER / ROLLED UP: L 42,5 CM x W 13 CM / UNFOLDED: L 42,5 CM x W 41,5 CM

9788 / 4002293978802

CONTENT

4473 SHARPENING STEEL / 26 CM
4582/23 COOK'S KNIFE / 23 CM
4517 CONFECTIONER'S KNIFE / 26 CM
4552 FILLET KNIFE / 16 CM
4060 PARING KNIFE / 10 CM
7370 KNIFE ROLL



Cook's cases

COOK'S STARTER SET / WITH 5 PIECES

WEIGHT: 880 G / MATERIAL: ARTIFICIAL LEATHER / ROLLED UP: L 42,5 CM x W 13 CM / UNFOLDED: L 42,5 CM x W 41,5 CM

9785 / 4002293978505

CONTENT

4473 SHARPENING STEEL / 26 CM
4562/23 COOK'S KNIFE / 23 CM
4606/14 BONING KNIFE / 14 CM
4552 FILLET KNIFE / 16 CM
4060 PARING KNIFE / 10 CM
7370 KNIFE ROLL



COOK'S STARTER SET / WITH 5 PIECES

WEIGHT: 860 G / MATERIAL: ARTIFICIAL LEATHER / ROLLED UP: L 42,5 CM x W 13 CM / UNFOLDED: L 42,5 CM x W 41,5 CM

9786 / 4002293978604

CONTENT

4473 SHARPENING STEEL / 26 CM
4561/23 COOK'S KNIFE / 23 CM
4501/23 CONFECTIONER'S KNIFE / 23 CM
4551 FILLET KNIFE / 16 CM
4023 PARING KNIFE / 8 CM
7370 KNIFE ROLL



Cook's cases (empty)

Knives not included.

GADGET CASE (EMPTY) FOR 6 PIECES

WEIGHT: 80 G / MATERIAL: ARTIFICIAL LEATHER / ROLLED UP: L 23,4 CM x W 8,7 CM / UNFOLDED: L 23,4 CM x W 28,7 CM

7373 / 4002293737300



KNIFE ROLL (EMPTY) FOR 6 PIECES

WEIGHT: 190 G / MATERIAL: ARTIFICIAL LEATHER / ROLLED UP: L 42,5 CM x W 13 CM / UNFOLDED: L 42,5 CM x W 41,5 CM

7370 / 4002293737003



KNIFE ROLL (EMPTY) FOR 9 PIECES

WEIGHT: 270 G / MATERIAL: ARTIFICIAL LEATHER / ROLLED UP: L 52,5 CM x W 13 CM / UNFOLDED: L 52,5 CM x W 48 CM

7371 / 4002293737102



KNIFE ROLL (EMPTY) FOR 6 PIECES

WEIGHT: 190 G / MATERIAL: ARTIFICIAL LEATHER WITH NYLON / ROLLED UP: L 42,5 CM x W 12 CM / UNFOLDED: L 42,5 CM x W 42,5 CM

7372 / 4002293737201



KNIFE ROLL (EMPTY) FOR 9 PIECES

WEIGHT: 250 G / MATERIAL: ARTIFICIAL LEATHER WITH NYLON / ROLLED UP: L 50,5 CM x W 12 CM / UNFOLDED: L 50,5 CM x W 47 CM

7374 / 4002293737409



Cook's cases (empty)

Knives not included.

COOK'S CASE (EMPTY) FOR 12 PIECES

WEIGHT: 830 G / MATERIAL: POLYESTER / ROLLED UP: L 50,5 CM x W 19 CM / UNFOLDED: L 71 CM x W 50,9 CM

7377 / 4002293737706



COOK'S CASE (EMPTY) FOR 10 PIECES

WEIGHT: 1,44 KG / MATERIAL: POLYESTER / ROLLED UP: L 50,5 CM x W 17 CM / UNFOLDED: 50,5 x 68,5 / WITH SHOULDERSTRAP

7378 / 4002293737805



COOK'S CASE (EMPTY) FOR 18 PIECES

WEIGHT: 1,8 KG / MATERIAL: POLYESTER / ROLLED UP: L 51,4 CM x W 27,6 CM / UNFOLDED: L 51,4 CM x W 89,5 CM / WITH SHOULDERSTRAP

7379 / 4002293737904



Cook's cases (empty)

Knives not included.

COOK'S CASE (EMPTY) FOR 12 PIECES

WEIGHT: 1,03 KG / MATERIAL: POLYESTER / ROLLED UP: L 48,5 x W 23,5 CM / UNFOLDED: L 48,5 x W 47 CM / WITH SHOULDERSTRAP AND COMBINATION LOCK

7381 / 4002293738109



7381 & 7282



7381



7382

COOK'S CASE (EMPTY) FOR 20 PIECES

WEIGHT: 1,49 KG / MATERIAL: POLYESTER / ROLLED UP: L 48 x W 24 CM / UNFOLDED: L 48 x W 48 CM / WITH SHOULDERSTRAP AND COMBINATION LOCK

7382 / 4002293738208



Blade guard

The special interior coating of all guards prevents the blades from being scratched.

9920-1 / 4002293992013

WEIGHT: 6 G / MATERIAL: POLYSTYROL / BLADE GUARD WIDTH: 2,5 CM / FOR KNIVES UP TO 12 CM



9920-2 / 4002293992020

WEIGHT: 11 G / MATERIAL: POLYSTYROL / BLADE GUARD WIDTH: 2,5 CM / FOR KNIVES UP TO 20 CM



9920-3 / 4002293992037

WEIGHT: 19 G / MATERIAL: POLYSTYROL / BLADE GUARD WIDTH: 3 CM / FOR KNIVES UP TO 26 CM



9920-4 / 4002293992044

WEIGHT: 27 G / MATERIAL: POLYSTYROL / BLADE GUARD WIDTH: 3 CM / FOR KNIVES UP TO 32 CM



9920-5 / 4002293992051

WEIGHT: 22 G / MATERIAL: POLYSTYROL / BLADE GUARD WIDTH: 5 CM / FOR KNIVES UP TO 20 CM



9920-6 / 4002293992068

WEIGHT: 29 G / MATERIAL: POLYSTYROL / BLADE GUARD WIDTH: 5 CM / FOR KNIVES UP TO 26 CM



Magnetic blade guard

Magnets inside the guards hold the knives in a safe position.

9921-1 / 4002293992112

WEIGHT: 50 G / MATERIAL: POLYPROPYLEN / BLADE GUARD WIDTH: 2,5 CM / FOR KNIVES UP TO 16 CM



9921-2 / 4002293992129

WEIGHT: 100 G / MATERIAL: POLYPROPYLEN / BLADE GUARD WIDTH: 3,5 CM / FOR KNIVES UP TO 26 CM



9921-3 / 4002293992136

WEIGHT: 150 G / MATERIAL: POLYPROPYLEN / BLADE GUARD WIDTH: 5,5 CM / FOR KNIVES UP TO 26 CM



9921-4 / 4002293992143

WEIGHT: 110 G / MATERIAL: POLYPROPYLEN / BLADE GUARD WIDTH: 5,5 CM / FOR KNIVES UP TO 20 CM



9921-5 / 4002293992150

WEIGHT: 200 G / MATERIAL: POLYPROPYLEN / BLADE GUARD WIDTH: 8,5 CM / FOR KNIVES UP TO 20 CM



Sharpening

Preparation is only really effortless with consistently sharpened tools

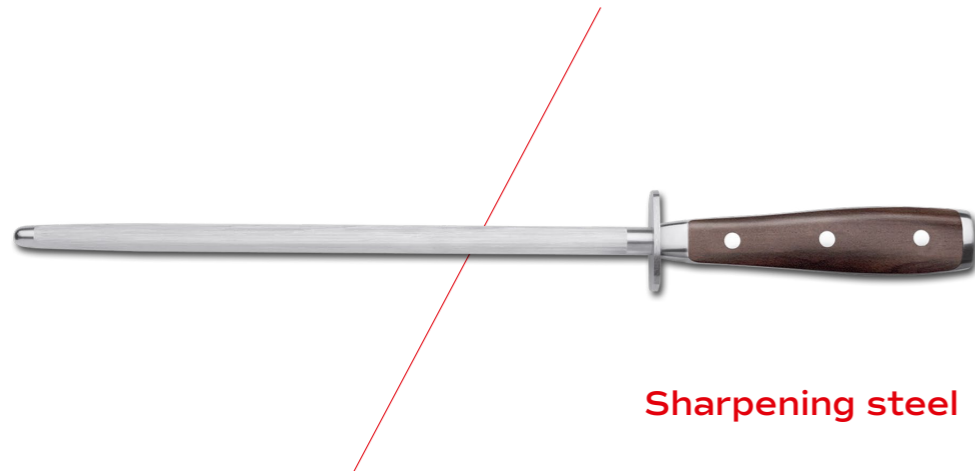

Sharpening steel

ONLY A SHARP BLADE IS A SAFE BLADE

Keeping the blade's edge as sharp as possible at all times is very important for safe cutting, since the balance of a blunt blade can be dangerous when additional force is added and can lead to injuries.

No matter how high quality and exceptionally good at cutting a knife is made, even the best knives lose their sharpness over time through wear and tear on the food items or chopping board. To reproduce this excellent cutting quality in the everyday kitchen, we offer a variety of solutions to hone and sharpen – for safe, efficient and pleasurable cutting at any time.



Easy Edge

ELECTRIC KNIFE SHARPENER

WEIGHT: 660 G / L 17,5 CM x W 11 CM x H 12,5 CM / EU, STECKER C

4341 / 4002293434100 / EU, PLUG C

4341-2 / 4002293434124 / GB, PLUG G

4341-3 / 4002293434131 / AUSTRALIA / NZ, PLUG I



LEVELS OF SHARPNESS

3	SHAPE	HIGH	Reshapes damaged blade edges.
2	SHARPEN	MEDIUM	Resharpens dull blade edges.
1	REFINE	LOW	Polishes and maintains blade edge sharpness.

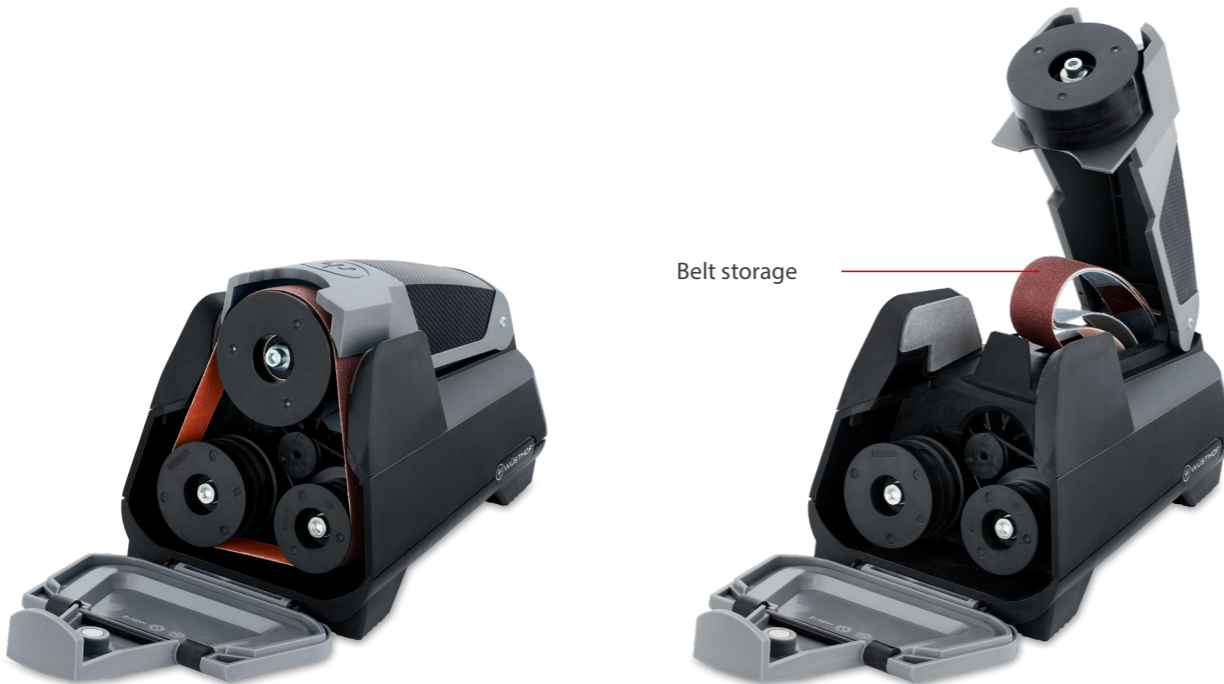

UPGRADE SET

7918 / 4002293791807

CONTENT

ASIAN BLADE GUIDE
(FOR ASIAN STYLE KNIVES)

SHARPENING BELTS:

1 x COARSE / 120ZA

1 x MEDIUM / 120

1 x FINE / X30 A0

1 x ULTRA FINE / X4 A0



COARSE / 120ZA



MEDIUM / 120



FINE / X30 A0



ULTRA FINE / X4 A0

SPARE SET

7918-1 / 4002293791814

CONTENT

SHARPENING BELTS:

1 x COARSE / 120ZA

2 x MEDIUM / 120

1 x FINE / X30 A0

1 x ULTRA FINE / X4 A0



Sharpening steel

IKON

WEIGHT: 273 G / ROD LENGTH: 26 CM / TOTAL LENGTH: 37,5 CM / FINE

4968 / 4002293496801



CLASSIC IKON

WEIGHT: 288 G / ROD LENGTH: 26 CM / TOTAL LENGTH: 37,5 CM / FINE

4468 / 4002293446806



CLASSIC IKON

WEIGHT: 288 G / ROD LENGTH: 26 CM / TOTAL LENGTH: 37,5 CM / FINE

4468-0 / 4002293246802



CLASSIC

WEIGHT: 281 G / ROD LENGTH: 26 CM / TOTAL LENGTH: 37,1 CM

4472 / 4002293447209



GRAND PRIX II

WEIGHT: 277 G / ROD LENGTH: 26 CM / TOTAL LENGTH: 37 CM

4477 / 4002293447704



Sharpening steel

4465/23 / 4002293446516

WEIGHT: 179 G / ROD LENGTH: 23 CM / TOTAL LENGTH: 34,8 CM / FINE



4463/18 / 4002293446318

WEIGHT: 171 G / ROD LENGTH: 18 CM / TOTAL LENGTH: 32,8 CM



4463/23 / 4002293446325

WEIGHT: 200 G / ROD LENGTH: 23 CM / TOTAL LENGTH: 37,6 CM



4473 / 4002293447308

WEIGHT: 263 G / ROD LENGTH: 26 CM / TOTAL LENGTH: 40 CM



4460/23 / 4002293446028

WEIGHT: 209 G / ROD LENGTH: 23 CM / TOTAL LENGTH: 37,1 CM



4462 / 4002293446202

WEIGHT: 243 G / ROD LENGTH: 20 CM / TOTAL LENGTH: 35,5 CM / OVAL



Sharpening steel

4474/26 / 4002293447414

WEIGHT: 361 G / ROD LENGTH: 26 CM / TOTAL LENGTH: 41,6 CM



4474/32 / 4002293447421

WEIGHT: 413 G / ROD LENGTH: 32 CM / TOTAL LENGTH: 46,8 CM



4470/26 / 4002293447018

WEIGHT: 348 G / ROD LENGTH: 26 CM / TOTAL LENGTH: 40,5 CM



4470/29 / 4002293447025

WEIGHT: 374 G / ROD LENGTH: 29 CM / TOTAL LENGTH: 42,5 CM



4470/32 / 4002293447032

WEIGHT: 437 G / ROD LENGTH: 32 CM / TOTAL LENGTH: 45 CM



4471 / 4002293447100

WEIGHT: 430 G / ROD LENGTH: 32 CM / TOTAL LENGTH: 47,6 CM / OVAL



Diamond knife sharpener

4480 / 4002293448008

WEIGHT: 173 G / ROD LENGTH: 23 CM / TOTAL LENGTH: 37,3 CM / DIAMOND COATED



4481 / 4002293448107

WEIGHT: 268 G / ROD LENGTH: 26 CM / TOTAL LENGTH: 40,8 CM / DIAMOND COATED



4482 / 4002293448206

WEIGHT: 177 G / ROD LENGTH: 23 CM / TOTAL LENGTH: 37,6 CM / DIAMOND COATED / FINE



4483 / 4002293448305

WEIGHT: 270 G / ROD LENGTH: 26 CM / TOTAL LENGTH: 40,7 CM / DIAMOND COATED / FINE

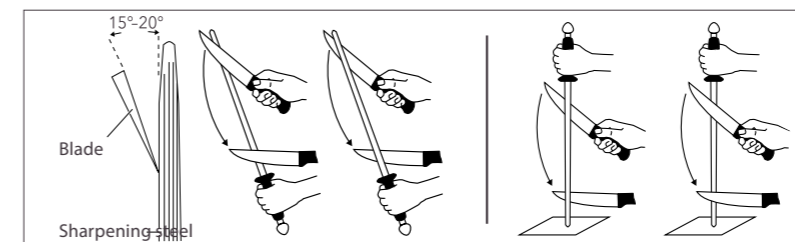

After extended use blades may be easily resharpened on a WÜSTHOF steel. Simply hold the blade at a ca. 15 - 20 degree angle and draw down across each side of the steel.

Ceramic sharpener

4455 / 4002293445502

WEIGHT: 215 G / ROD LENGTH: 26 CM / TOTAL LENGTH: 38 CM / GRIT: J 800



4456 / 4002293445601

WEIGHT: 215 G / ROD LENGTH: 26 CM / TOTAL LENGTH: 38 CM / GRIT: J 3000



Polishing steel

4475 / 4002293447506

WEIGHT: 495 G / ROD LENGTH: 32 CM / TOTAL LENGTH: 48,4 CM / FINE



4476 / 4002293447605

WEIGHT: 499 G / ROD LENGTH: 32 CM / TOTAL LENGTH: 47,5 CM / OVAL / EXTRA FINE



Whetstone

WHETSTONE INCL. NON-SLIP HOLDER AND RESHAPING STONE

WEIGHT: 1.402 G / L 22 CM X W 8 CM X H 3 CM / GRIT: J 1000 / J 4000

4453 / 4002293445304

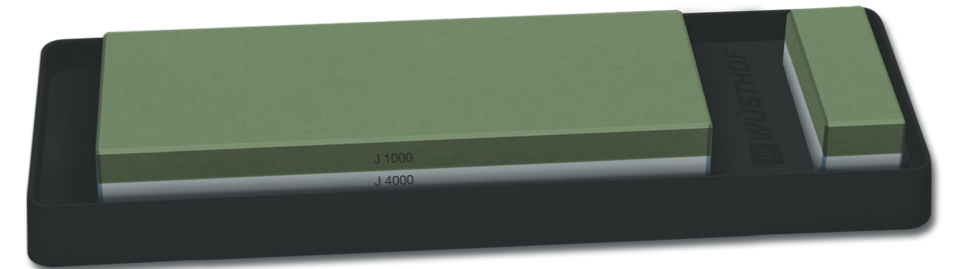

4451 / 4002293445106

WEIGHT: 861 G / L 20 CM x W 6 CM x H 3 CM / GRIT: J 1000 / J 3000 / WITH HOLDER



4452 / 4002293445205

WEIGHT: 852 G / L 20 CM x W 6 CM x H 3 CM / GRIT: J 3000 / J 8000 / WITH HOLDER



4450 / 4002293445007

WEIGHT: 348 G / L 15 CM x W 5 CM x H 2,5 CM / GRIT: J 400 / J 2000

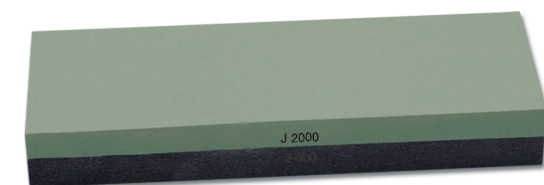

J = Japanese Industrial Standard

NON-SLIP HOLDER FOR WHETSTONES

WEIGHT: 160 G / L 32,5 CM x W 11,5 CM x H 2 CM

7919-1 / 4002293791913



SHARPENING GUIDE

WEIGHT: 62 G / L 6 CM x W 6 CM x H 1,5 CM / ANGLE 14°

4349 / 4002293434902



RESHAPING STONE

WEIGHT: 291 G / L 10 CM x W 5 CM x H 3 CM / GRIT: J 80

4454 / 4002293445403



Knife sharpener

4343 / 4002293434308

WEIGHT: 150 G / TOTAL LENGTH: 16,4 CM / RODS: CERAMIC



4347 / 4002293434704

WEIGHT: 235 G / TOTAL LENGTH: 17,9 CM / RODS: CERAMIC / CARBID



4348 / 4002293434803

WEIGHT: 272 G / TOTAL LENGTH: 21 CM / RODS: CERAMIC / DIAMOND





A perfect cutting board. The optimal partner for sharp blades

PRACTICAL TOOLS - FOR WELL-MAINTAINED KNIVES

Dicing vegetables, cutting meat, chopping herbs, slicing fruit – good knives make work easy and great fun.

By using professional cutting boards knives stay sharp for longer. The natural composition of high quality wood and durability of the special synthetic material used by us preserve the sensitive blades and ensure the edge is not damaged by hard, unsuitable surfaces. As a result, the knives need to be resharpened less, efficiency in the kitchen increases and the work is precise, clean and safe.

That is why high-performance cutting boards are also part of the ideal kitchen set-up together with first-class knives.

Cutting board covers

made from sustainable natural fibre material

retaining sharpness / dishwasher safe / can be used on both sides / extra light / versatile

7310 / 4002293731001

WEIGHT: 411 G / MATERIAL: NATURAL FIBRES / L 30 CM x W 18 CM x H 0,6 CM



7311 / 4002293731100

WEIGHT: 622 G / MATERIAL: NATURAL FIBRES / L 38 CM x W 23 CM x H 0,6 CM / WITH JUICE GROOVE



7312 / 4002293731209

WEIGHT: 934 G / MATERIAL: NATURAL FIBRES / L 46 CM x W 28 CM x H 0,6 CM / WITH JUICE GROOVE



Cutting board covers

SET WITH 2 CUTTING BOARD COVERS

7313 / 4002293731308

CONTENT 7311 + 7312



SET WITH 3 CUTTING BOARD COVERS

7314 / 4002293731407

CONTENT 7310 + 7311 + 7312



Cutting blocks

Solid beech wood

retaining sharpness / natural and hygienic / environmentally sustainable

7288-1 / 4002293728810

WEIGHT: 3,52 KG / L 40 CM x W 30 CM x H 5 CM



7289-1 / 4002293728926

WEIGHT: 6,22 KG / L 50 CM x W 40 CM x H 5 CM



Cutting and serving boards

Solid beech wood

retaining sharpness / natural and hygienic / environmentally sustainable

7291-1 / 4002293729114

WEIGHT: 828 G / L 31,7 CM x W 21 CM x H 2,8 CM



7291-2 / 4002293729121

WEIGHT: 1,5 KG / L 47,5 CM x W 21 CM x H 2,8 CM



7291-3 / 4002293729138

WEIGHT: 1,5 KG / L 74,5 CM x W 12,5 CM x H 2,8 CM



Cutting boards

Thermo beech wood

water-repellent / natural finish – no artificial coating / resistant to water, shrinking and swelling

7292 / 4002293729206

WEIGHT: 2,98 KG / MATERIAL: THERMO BEECH WOOD, STAINLESS STEEL / L 40 CM x W 25 CM x H 3 CM



7295 / 4002293729503

WEIGHT: 1,87 K G / MATERIAL: THERMO BEECH WOOD / L 40 CM x W 25 CM x H 3 CM



7296 / 4002293729602

WEIGHT: 3,86 KG / MATERIAL: THERMO BEECH WOOD / L 50 CM x W 35 CM x H 4 CM



Cutting boards

Thermo beech wood

water-repellent / natural finish – no artificial coating / resistant to water, shrinking and swelling

7293 / 4002293729305

WEIGHT: 3,14 KG / MATERIAL: THERMO BEECH WOOD, STAINLESS STEEL / L 40 CM x W 25 CM x H 4 CM



7294 / 4002293729404

WEIGHT: 5,67 KG / MATERIAL: THERMO BEECH WOOD, STAINLESS STEEL / L 50 CM x W 35 CM x H 4 CM



CARE INSTRUCTIONS FOR ALL WOOD CUTTING BOARDS:

Never wash in the dishwasher. To care for your cutting boards, you can oil them lightly with cooking oil when dry from time to time. Apply using a cotton cloth. Then allow it to soak in and dry over night. This way you can maintain the moisture barrier.

Cutting boards

TPU – Thermoplastic Polyurethane

retaining sharpness / scratch-resistant / dishwasher-safe / can be sterilized

7297-2 / 4002293372976

7297g-2 / 4002293472973

7297r-2 / 4002293572970

WEIGHT: 230 G / L 26 CM x W 17 CM x H 0,4 CM / WITH JUICE GROOVE



7297 / 4002293729701

7297g / 4002293729718

7297r / 4002293729725

WEIGHT: 113 G / L 26 CM x W 17 CM x H 0,2 CM



7298 / 4002293729800

7298g / 4002293729817

7298r / 4002293729824

WEIGHT: 491 G / L 38 CM x W 25 CM x H 0,4 CM / WITH JUICE GROOVE



7299 / 4002293729909

7299g / 4002293729916

7299r / 4002293729923

WEIGHT: 930 G / L 53 CM x W 32 CM x H 0,4 CM / WITH JUICE GROOVE



Poultry shears

5501 / 4002293550107

WEIGHT: 329 G / TOTAL LENGTH: 26,5 CM / STAINLESS



5505 / 4002293550503

WEIGHT: 341 G / TOTAL LENGTH: 25,4 CM / STAINLESS



5512 / 4002293551203

WEIGHT: 346 G / TOTAL LENGTH: 24,5 CM / STAINLESS / COME APART



5508 / 4002293550800

WEIGHT: 197 G / TOTAL LENGTH: 25,5 CM / STAINLESS



5509 / 4002293550909

WEIGHT: 154 G / TOTAL LENGTH: 25 CM / STAINLESS / DISPLAY WITH 6 SHEARS



Kitchen shears

5550-1 / 4002293555010

WEIGHT: 126 G / TOTAL LENGTH: 20 CM / STAINLESS



5552-1 / 4002293555218

WEIGHT: 126 G / TOTAL LENGTH: 20 CM / STAINLESS



5551-1 / 4002293555119

WEIGHT: 126 G / TOTAL LENGTH: 20 CM / STAINLESS



5558 / 4002293555805

WEIGHT: 116 G / TOTAL LENGTH: 20,2 CM / STAINLESS / COME APART



5556 / 4002293555607

WEIGHT: 120 G / TOTAL LENGTH: 20,6 CM / STAINLESS



KITCHEN SHEARS

WEIGHT: 145 G / TOTAL LENGTH: 17,6 CM / STAINLESS

5553 / 4002293555300



KITCHEN SHEARS

WEIGHT: 216 G / TOTAL LENGTH: 20,3 CM / STAINLESS

5563 / 4002293556307



FISH SHEARS

WEIGHT: 255 G / TOTAL LENGTH: 20,8 CM / VERCHROMT

5561 / 4002293556109



KITCHEN/FISH SHEARS

WEIGHT: 261 G / TOTAL LENGTH: 21,1 CM / STAINLESS

5564 / 4002293556406



HOUSEHOLD SCISSORS

WEIGHT: 40 G / TOTAL LENGTH: 12,5 CM / STAINLESS / MATT FINISH

5324/13 / 4002293532431



HOUSEHOLD SCISSORS

WEIGHT: 55 G / TOTAL LENGTH: 15,5 CM / STAINLESS / MATT FINISH

5324/16 / 4002293532417



HOUSEHOLD SCISSORS

WEIGHT: 80 G / TOTAL LENGTH: 18 CM / STAINLESS / MATT FINISH

5324/18 / 4002293532424



HOUSEHOLD/TAILOR'S SHEARS

WEIGHT: 94 G / TOTAL LENGTH: 18,1 CM / STAINLESS / MATT FINISH

5334/18 / 4002293533407



Meat forks

IKON

WEIGHT: 173 G / FORK LENGTH: 16 CM / TOTAL LENGTH: 26,8 CM

4914/16 / 4002293491424



CLASSIC IKON

WEIGHT: 180 G / FORK LENGTH: 16 CM / TOTAL LENGTH: 26,8 CM

4414/16 / 4002293441429



CLASSIC IKON

WEIGHT: 180 G / FORK LENGTH: 16 CM / TOTAL LENGTH: 26,8 CM

4414-0/16 / 4002293241425



CLASSIC

4410/16 / 4002293441030 / WEIGHT: 130 G / FORK LENGTH: 16 CM / TOTAL LENGTH: 27,9 CM

4410/18 / 4002293441047 / WEIGHT: 136 G / FORK LENGTH: 18 CM / TOTAL LENGTH: 28,1 CM

4410/20 / 4002293441054 / WEIGHT: 155 G / FORK LENGTH: 20 CM / TOTAL LENGTH: 30,5 CM



GRAND PRIX II

WEIGHT: 136 G / FORK LENGTH: 16 CM / TOTAL LENGTH: 28 CM

4417 / 4002293441733



Meat forks

4411/16 / 4002293441115

WEIGHT: 140 G / FORK LENGTH: 16 CM / TOTAL LENGTH: 26,6 CM / CURVED



4411/20 / 4002293441122

WEIGHT: 179 G / FORK LENGTH: 20 CM / TOTAL LENGTH: 31,2 CM / CURVED



4413/18 / 4002293441344

WEIGHT: 145 G / FORK LENGTH: 18 CM / TOTAL LENGTH: 29,1 CM



Kitchen forks

GOURMET

WEIGHT: 74 G / FORK LENGTH: 14 CM / TOTAL LENGTH: 24,5 CM

4400/14 / 4002293440026



GOURMET

WEIGHT: 80 G / FORK LENGTH: 16 CM / TOTAL LENGTH: 26,5 CM

4400/16 / 4002293440033



SILVERPOINT

WEIGHT: 80 G / FORK LENGTH: 16 CM / TOTAL LENGTH: 28,5 CM

4407 / 4002293440705



Spatulas

4430/15 / 4002293443010

WEIGHT: 76 G / SPATULA LENGTH: 15 CM / TOTAL LENGTH: 27,5 CM



4430/20 / 4002293443027

WEIGHT: 92 G / SPATULA LENGTH: 20 CM / TOTAL LENGTH: 32,5 CM



4430/25 / 4002293443034

WEIGHT: 108 G / SPATULA LENGTH: 25 CM / TOTAL LENGTH: 37,5 CM



4430/30 / 4002293443041

WEIGHT: 111 G / SPATULA LENGTH: 30 CM / TOTAL LENGTH: 42,5 CM

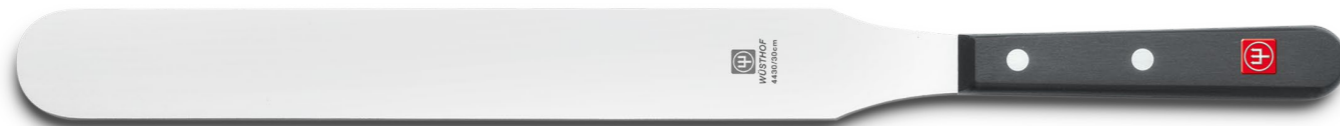

4434 / 4002293443409

WEIGHT: 75 G / SPATULA LENGTH: 12 CM / TOTAL LENGTH: 27,9 CM



4433 / 4002293443300

WEIGHT: 73 G / SPATULA LENGTH: 17 CM / TOTAL LENGTH: 29,1 CM



Spatulas

4435 / 4002293443508

WEIGHT: 85 G / SPATULA LENGTH: 12 CM / TOTAL LENGTH: 28 CM



4438 / 4002293443805

WEIGHT: 117 G / SPATULA LENGTH: 12 CM / TOTAL LENGTH: 28,5 CM



4436 / 4002293443607

WEIGHT: 166 G / SPATULA LENGTH: 20 CM / TOTAL LENGTH: 36,5 CM



4437 / 4002293443713

WEIGHT: 114 G / SPATULA LENGTH: 25 CM / TOTAL LENGTH: 41,4 CM



Spatulas

4421 / 4002293442105

WEIGHT: 38 G / SPATULA LENGTH: 10 CM / TOTAL LENGTH: 21,6 CM



4420/20 / 4002293442044

WEIGHT: 79 G / SPATULA LENGTH: 20 CM / TOTAL LENGTH: 35,3 CM



4420/25 / 4002293442051

WEIGHT: 82 G / SPATULA LENGTH: 25 CM / TOTAL LENGTH: 37 CM



4426 / 4002293442617

WEIGHT: 115 G / SPATULA LENGTH: 14 CM / TOTAL LENGTH: 29 CM



4425 / 4002293442501

WEIGHT: 76 G / SPATULA LENGTH: 12 CM / TOTAL LENGTH: 27,4 CM



4424 / 4002293442402

WEIGHT: 62 G / SPATULA LENGTH: 12 CM / TOTAL LENGTH: 27,5 CM



POTATO PEELING FORK

WEIGHT: 29 G / TOTAL LENGTH: 15,5 CM

4250 / 4002293425009



PEELER

WEIGHT: 41 G / TOTAL LENGTH: 17,4 CM

4072 / 4002293407203



SWIVEL POTATO PEELER

WEIGHT: 51 G / TOTAL LENGTH: 18,8 CM

4075 / 4002293407500



ASPARAGUS PEELING KNIFE

WEIGHT: 49 G / TOTAL LENGTH: 22 CM

4082 / 4002293408200



JULIENNE PEELER

WEIGHT: 72 G / TOTAL LENGTH: 19,1 CM

4076 / 4002293407609



DECORATING KNIFE

WEIGHT: 38 G / BLADE LENGTH: 9 CM / BLADE WIDTH: 1,7 CM / TOTAL LENGTH: 19,7 CM

4206 / 4002293420608



LEMON ZESTER

WEIGHT: 34 G / TOTAL LENGTH: 15 CM

3086 / 4002293308609



CHANNEL KNIFE

WEIGHT: 34 G / TOTAL LENGTH: 15,7 CM

3066 / 4002293306605



ORANGE PEELER

WEIGHT: 34 G / TOTAL LENGTH: 15,5 CM

3064 / 4002293306407



APPLE CORER

WEIGHT: 40 G / TOTAL LENGTH: 18,8 CM / DIAMETER: 1,5 CM

4245 / 4002293424507



APPLE CORER

WEIGHT: 43 G / TOTAL LENGTH: 21,2 CM / DIAMETER: 2 CM

4246 / 4002293424606



MELON BALER

4240/1.0 / 4002293424019 / WEIGHT: 34 G / LENGTH: 14,7 CM / Ø 1,0 CM

4240/1.5 / 4002293424026 / WEIGHT: 33 G / LENGTH: 15,4 CM / Ø 1,5 CM

4240/1.8 / 4002293424033 / WEIGHT: 35 G / LENGTH: 15,5 CM / Ø 1,8 CM

4240/2.2 / 4002293424040 / WEIGHT: 34 G / LENGTH: 15,7 CM / Ø 2,2 CM

4240/2.5 / 4002293424057 / WEIGHT: 35 G / LENGTH: 16,2 CM / Ø 2,5 CM

4240/3.0 / 4002293424064 / WEIGHT: 40 G / LENGTH: 16,7 CM / Ø 3,0 CM

4241 / 4002293424101 / WEIGHT: 45 G / LENGTH: 16,5 CM / Ø 2,2 & 2,5 CM



GRAPEFRUIT KNIFE

WEIGHT: 40 G / TOTAL LENGTH: 20,8 CM

3044 / 4002293304403



CHEESE CUTTER

WEIGHT: 52 G / TOTAL LENGTH: 26 CM

3112 / 4002293311203



CHEESE PLANE

WEIGHT: 66 G / TOTAL LENGTH: 22,7 CM

3124 / 4002293312408



PIZZA CUTTER

WEIGHT: 73 G / TOTAL LENGTH: 17,9 CM

4274 / 4002293427409



Oyster opener

4282 / 4002293428208

WEIGHT: 75 G / TOTAL LENGTH: 16,1 CM



4281 / 4002293428109

WEIGHT: 116 G / TOTAL LENGTH: 16,2 CM

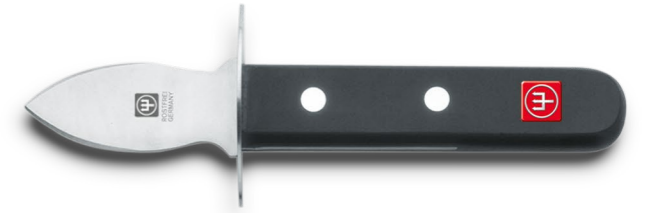

4284 / 4002293428406

WEIGHT: 121 G / TOTAL LENGTH: 16,2 CM



CUT RESISTANT GLOVE

7669s / 4002293769905

7669I / 4002293769929

SIZE 7 / WEIGHT: 34 G

SIZE 9 / WEIGHT: 38 G



MEAT TENDERIZER

WEIGHT: 1352 G / WORKING LENGTH: 14 CM / TOTAL LENGTH: 32,2 CM

4702 / 4002293470207



SET OF LOBSTER FORKS

WEIGHT: 27 G / TOTAL LENGTH: 20,5 CM / STAINLESS / CONTENT : 4 PIECES

3320 / 4002293332000



LOBSTER PRONGS

WEIGHT: 170 G / TOTAL LENGTH: 19,4 CM / STAINLESS

5864 / 4002293586403



FISCHBONE PLIERS

WEIGHT: 121 G / TOTAL LENGTH: 18,5 CM / STAINLESS

5880 / 4002293588001



PLATING TONGS

WEIGHT: 108 G / TOTAL LENGTH: 30 CM / STAINLESS

7725-1 / 4002293177250



GOURMET PINZETTE

WEIGHT: 34 G / TOTAL LENGTH: 20 CM / STAINLESS

7726 / 4002293772608



FISHBONE TWEEZERS

WEIGHT: 47 G / TOTAL LENGTH: 14 CM / STAINLESS

7721 / 4002293772110



FISHBONE TWEEZERS

WEIGHT: 21 G / TOTAL LENGTH: 15 CM / STAINLESS

7720 / 4002293772011



TRUSSING NEEDLE

WEIGHT: 10 G / TOTAL LENGTH: 18 CM / STAINLESS

4385 / 4002293438504



LARDING NEEDLE

WEIGHT: 12 G / TOTAL LENGTH: 20 CM / STAINLESS / WITH FLAP

4380 / 4002293438009



Spare parts

KNIFE CARE OIL

7905 / 4002293790503

SPRING FOR 5501, 5502 UND 5505

7960 / 4002293796017

COMBINATION LOCK

7910 / 4002293791005

SPRING FOR 5508

7962 / 4002293796208

REPLACEMENT WIRE FOR 3112

7920 / 4002293792002

SHUTTER AND SCREW FOR 5512

7964 / 4002293796406

SPARE PARTS FOR 4348

7923 / 4002293792309

SCREW AND NUT FOR 5556

7965 / 4002293796505

END CAPS FOR MAGNETIC HOLDERS

7924 / 4002293792408

CERAMIC SHARPENER 4455 WITHOUT HANDLE

7970 / 4002293797007

SCREWS AND BLADE FOR 4075

7939 / 4002293793900

CERAMIC SHARPENER 4456 WITHOUT HANDLE

7971 / 4002293797106

BRACKET FOR 4082

7940 / 4002293794006

INSERT FOR KNIFE BLOCK 7272 + 7278

7972 / 4002293797205

SCREW AND NUT FOR 4082

7941 / 4002293794105

WOOD INSERT FOR CHOPPING BOARD 7292

7992 / 4002293799209

SPRING FOR 5512

7959 / 4002293795904

DESCRIPTION	ITEM	SERIES	EAN 4002293	PAGE
Apple corer	4245		424507	220
Apple corer	4246		424606	220
Asparagus peeling knife	4082		408200	219
Blade guard	9920-1		992013	188
Blade guard	9920-2		992020	188
Blade guard	9920-3		992037	188
Blade guard	9920-4		992044	188
Blade guard	9920-5		992051	188
Blade guard	9920-6		992068	188
Blade guard	9921-1		992112	189
Blade guard	9921-2		992129	189
Blade guard	9921-3		992136	189
Blade guard	9921-4		992143	189
Blade guard	9921-5		992150	189
Boning knife	4958	IKON	495804	50
Boning knife	4616	CLASSIC IKON	461601	60
Boning knife	4616-0	CL IKON creme	261607	72
Boning knife	4601	CLASSIC	460109	86
Boning knife	4602	CLASSIC	460208	86
Boning knife	4603	CLASSIC	460307	86
Boning knife	4610/16	CLASSIC	461014	86
Boning knife	4615	GRAND PRIX II	461502	102
Boning knife	4607	GOURMET	460703	118
Boning knife	4606/14	GOURMET	460611	118
Boning knife	4606/16	GOURMET	460628	118
Boning knife	4605	SILVERPOINT	460505	127
Bracket for 4082	7940		794006	223
Bread knife	3452/23	URBAN FARMER	345284	34
Bread knife	3752/23	CRAFTER	737522	26
Bread knife	3950/23	EPICURE	395050	42
Bread knife	4963/23	IKON	496351	51
Bread knife	4966/20	IKON	496610	51
Bread knife	4966/23	IKON	496627	51
Bread knife	4163/23	CLASSIC IKON	416359	61
Bread knife	4166/20	CLASSIC IKON	416618	61
Bread knife	4166/23	CLASSIC IKON	416625	61
Bread knife	4163-0/23	CL IKON creme	216355	73
Bread knife	4166-0/20	CL IKON creme	216645	73
Bread knife	4166-0/23	CL IKON creme	246659	73
Bread knife	4128	CLASSIC	412801	83
Bread knife	4149	CLASSIC	414904	83
Bread knife	4150	CLASSIC	415000	83
Bread knife	4151	CLASSIC	415109	83
Bread knife	4152/23	CLASSIC	415208	83
Bread knife	4155	GRAND PRIX II	415505	103
Bread knife	4165	GRAND PRIX II	416502	103
Brunch knife	4101	GOURMET	410104	113
Bread knife	4143	GOURMET	414300	114
Bread knife	4145	GOURMET	414508	114
Bread knife	4141	SILVERPOINT	414102	127
Brunch knife	4103	SILVERPOINT	410302	126
Butcher knife	4657-1/20	CLASSIC	465746	94

DESCRIPTION	ITEM	SERIES	EAN 4002293	PAGE
Carving knife	3723/16	CRAFTER	437231	26
Carving knife	3723/20	CRAFTER	537238	26
Carving knife	4906/20	IKON	490649	50
Carving knife	4506/20	CLASSIC IKON	450643	63
Carving knife	4506/23	CLASSIC IKON	450650	63
Carving knife	4506-0/20	CL IKON creme	250649	72
Carving knife	4522/20	CLASSIC	452241	88
Carving knife	4522/23	CLASSIC	452258	88
Carving knife	4524/20	CLASSIC	452418	89
Carving knife	4524/23	CLASSIC	452425	89
Carving knife	4525/20	GRAND PRIX II	452548	102
Carving set, 2 pcs.	9647	CLASSIC IKON	964706	142
Carving set, 2 pcs.	9740	CLASSIC	974002	144
Carving set, 2 pcs.	9645	GRAND PRIX II	964508	147
Carving set, 2 pcs.	9704	GOURMET	970400	149
Carving set, 2 pcs.	9813	SILVERPOINT	981307	152
Ceramic sharpener	4456		445601	195
Ceramic sharpener	4455		445502	195
Ceramic sharpener 4455without handle	7970		797007	223
Ceramic sharpener 4456without handle	7971		797106	223
Chai Dao	4177	CLASSIC	417707	92
Chai Dao	8888	CLASSIC	888804	92
Channel knife	3066		306605	219
Charcuterie set, 3 pcs.	9548		954806	138
Cheese cutter	3112		311203	220
Cheese knife	4800		480008	136
Cheese knife	4802		480206	136
Cheese knife	4812		481203	136
Cheese knife	3108	GOURMET	310879	136
Cheese knife	3102	CLASSIC	310206	136
Cheese knife	3103	CLASSIC	310305	136
Cheese plane	3124		312408	220
Chef's attaché case, 25 pcs.	9774-1		977416	180
Chef's attaché case, 18 pcs.	9778	CL/GOUR	977805	181
Chef's attaché case, 18 pcs.	9771	GP/SILVER.	977102	181
Chef's attache case (empty)	7384		738406	180
Chef's attaché case (empty)	7388		738802	181
Chinese chef's knife	4688		468808	135
Chinese chef's knife	4691/18		469119	135
Chinese chef's knife	4691/20		469126	135
Chinese chef's knife	4692/18	SILVERPOINT	469201	135
Chinese chef's knife	4692/20	SILVERPOINT	469218	135
Chinese chef's knife	4973/18	IKON	497334	134
Chinese chef's knife	4686/18	CLASSIC	468617	134
Chinese chef's knife	4673/18	CLASSIC IKON	467337	134
Chinese chef's knife	4673-0/18	CL IKON creme	267333	134
Cleaver	4684/16	SILVERPOINT	468440	132
Cleaver	4682/16	CLASSIC	468242	132
Cleaver	4680/16		468013	132
Cleaver	4680/18		468020	132
Cleaver	4680/20		468037	132
Cleaver	4685/16		468518	133

DESCRIPTION	ITEM	SERIES	EAN 4002293	PAGE
Cleaver	4685/19		468525	133
Cleaver	4685/21		468532	133
Cleaver	4685/24		468549	133
Combination lock	7910		791005	223
Confectioner's knife	4514	CLASSIC	451404	90
Confectioner's knife	4517	GOURMET	451701	116
Confectioner's knife	4501/23	SILVERPOINT	450100	127
Confectioner's knife	4501/26	SILVERPOINT	450117	127
Cook's case (empty)	7378		737805	186
Cook's case (empty)	7377		737706	186
Cook's case (empty)	7379		737904	186
Cook's case (empty)	7381		738109	187
Cook's case (empty)	7382		738208	187
Cook's case, 6 pcs.	9783	GP/SILVER.	978307	182
Cook's knife	3685/20	AEON	103327	19 NEU
Cook's knife	3781/16	CRAFTER	437811	26
Cook's knife	3781/20	CRAFTER	637815	26
Cook's knife	3481/16	URBAN FARMER	348155	34
Cook's knife	3481/20	URBAN FARMER	348179	34
Cook's knife	3982/16	EPICURE	398235	42
Cook's knife	3982/20	EPICURE	398259	42
Cook's knife	3982/24	EPICURE	398273	42
Cook's knife	3981/16	EPICURE	398143	43
Cook's knife	3981/20	EPICURE	398167	43
Cook's knife	4996/16	IKON	499628	52
Cook's knife	4996/20	IKON	499642	52
Cook's knife	4996/23	IKON	499659	52
Cook's knife	4596/16	CLASSIC IKON	459622	62
Cook's knife	4596/18	CLASSIC IKON	459639	62
Cook's knife	4596/20	CLASSIC IKON	459646	62
Cook's knife	4596/23	CLASSIC IKON	459653	62
Cook's knife	4596/26	CLASSIC IKON	459660	62
Cook's knife	4596-0/16	CL IKON creme	259628	74
Cook's knife	4596-0/20	CL IKON creme	259642	74
Cook's knife	4596-0/23	CL IKON creme	259659	74
Cook's knife	4582/12	CLASSIC	458205	84
Cook's knife	4582/14	CLASSIC	458212	84
Cook's knife	4582/16	CLASSIC	458229	84
Cook's knife	4582/18	CLASSIC	458236	84
Cook's knife	4582/20	CLASSIC	458243	84
Cook's knife	4582/23	CLASSIC	458250	85
Cook's knife	4582/26	CLASSIC	458267	85
Cook's knife	4572/20	CLASSIC	457246	86
Cook's knife	4582/32	CLASSIC	458274	91
Cook's knife	4581/16	CLASSIC	458120	92
Cook's knife	4581/20	CLASSIC	458144	92
Cook's knife	4581/23	CLASSIC	458151	92
Cook's knife Super Glider	4563/20	CLASSIC	456317	94
Cook's knife	4585/16	GRAND PRIX II	458526	104
Cook's knife	4585/18	GRAND PRIX II	458533	104
Cook's knife	4585/20	GRAND PRIX II	458540	104
Cook's knife	4585/23	GRAND PRIX II	458557	104

DESCRIPTION	ITEM	SERIES	EAN 4002293	PAGE
Cook's knife	4562/14	GOURMET	456201	114
Cook's knife	4562/16	GOURMET	456218	114
Cook's knife	4562/18	GOURMET	456225	114
Cook's knife	4562/23	GOURMET	456249	115
Cook's knife	4562/26	GOURMET	456256	115
Cook's knife	4562/20	GOURMET	456232	115
Cook's knife	4561/16	SILVERPOINT	456102	128
Cook's knife	4561/18	SILVERPOINT	456133	128
Cook's knife	4561/20	SILVERPOINT	456157	128
Cook's knife	4561/23	SILVERPOINT	456188	128
Cook's knife	4561/26	SILVERPOINT	456195	128
Cook's set, 4 pcs.	9750	CLASSIC	975009	145
Cook's set, 5 pcs.	9746	CLASSIC	974606	145
Cook's set, 6 pcs.	9751	CLASSIC	975108	145
Cook's starter set, 5 pcs.	9780	CL/GOUR	978000	183
Cook's starter set, 5 pcs.	9788	CL/GOUR	978802	183
Cook's starter set, 5 pcs.	9785	GOURMET	978505	184
Cook's starter set, 5 pcs.	9786	SILVERPOINT	978604	184
Curved meat fork	4411/16	CLASSIC	441115	215
Curved meat fork	4411/20	CLASSIC	441122	215
Cut resistant glove	7669I		769929	221
Cut resistant glove	7669s		769905	221
Cutting block	7288-1		728810	204
Cutting block	7289-1		728926	204
Cutting and serving board	7291-1		729114	205
Cutting and serving board	7291-2		729121	205
Cutting and serving board	7291-3		729138	205
Cutting board	7292		729206	206
Cutting board	7293		729305	206
Cutting board	7294		729404	206
Cutting board	7295		729503	206
Cutting board	7296		729602	206
Cutting board	7297-2		372976	208
Cutting board	7297g-2		472973	208
Cutting board	7297r-2		572970	208
Cutting board	7297		729701	208
Cutting board	7297g		729718	208
Cutting board	7297r		729725	208
Cutting board	7298		729800	209
Cutting board	7299		729909	209
Cutting board	7298g		729817	209
Cutting board	7298r		729824	209
Cutting board	7299g		729916	209
Cutting board	7299r		729923	209
Cutting board cover	7310		73101	203
Cutting board cover	7311		731100	203
Cutting board cover	7312		731209	203
Cutting board cover, 2 pcs.	7313		731308	204
Cutting board cover, 3 pcs.	7314		731407	204
Decorating knife	4204	GOURMET	420400	112
Decorating knife	4206	SILVERPOINT	420608	219
Diamond knife sharpener	4480		448008	194

DESCRIPTION	ITEM	SERIES	EAN 4002293	PAGE
Diamond knife sharpener	4481		448107	194
Diamond knife sharpener	4482		448206	194
Diamond knife sharpener	4483		448305	194
Electric knife sharpener - EU	4341		434100	192
Electric knife sharpener - GB	4341-2		434124	192
Electric knife sharpener - Australia / NZ	4341-3		434131	192
End caps for magnetic holders	7924		792408	223
Fillet knife	4956	IKON	495613	50
Fillet knife	4556	CLASSIC IKON	455617	60
Fillet knife	4626	CLASSIC IKON	462608	60
Fillet knife	4556-0	CL IKON creme	255606	72
Fillet knife	4622	CLASSIC	462202	87
Fillet knife	4550/16	CLASSIC	455013	87
Fillet knife	4550/18	CLASSIC	455020	87
Fillet knife	4625	GRAND PRIX II	462509	102
Fillet knife	4552	GOURMET	455204	115
Fillet knife	4551	SILVERPOINT	455105	127
Fish fillet knife	4518/16	CLASSIC	451817	87
Fish fillet knife	4518/20	CLASSIC	451824	87
Fish fillet knife	4618	GOURMET	461816	115
Fish shears	5561		556109	212
Fishbone pliers	5880		588001	222
Fishbone tweezers	7720		772011	222
Fishbone tweezers	7721		772110	222
Gadget case (empty), for 6 pcs.	7373		737300	185
Garnishing set, 6 pcs	9888	SILVERPOINT	988801	182
Gourmet tweezers	7726		772608	222
Grapefruit knife	3044		304403	220
Ham slicer	4530	CLASSIC	453002	89
Ham slicer	4531	CLASSIC	453101	89
Heavy cook's knife	4586/36	CLASSIC	458625	91
Holder, non-slip	7919-1		791913	200
Household scissors	5324/13		532431	213
Household scissors	5324/16		532417	213
Household scissors	5324/18		532424	213
Household/Tailor's shears	5334/18		533407	213
In-drawer knife organiser	7271		727103	177
In-drawer knife organiser	7270		727004	177
In-drawer knife organiser	7273		727301	177
In-drawer knife organiser	7279		727905	177
Insert for brush block 7272 + 7278	7972		797205	223
Julienne peeler	4076		407609	219
Kitchen fork	4400/14	GOURMET	440026	215
Kitchen fork	4400/16	GOURMET	440033	215
Kitchen fork	4407	SILVERPOINT	440705	215
Kitchen knife	4138/16	CLASSIC	413815	90
Kitchen knife	4139/16	CLASSIC	413914	90
Kitchen knife	4130/14	GOURMET	413013	118
Kitchen knife	4130/16	GOURMET	413020	118
Kitchen knife	4130/18	GOURMET	413037	118
Kitchen shears	5550-1		555010	211
Kitchen shears	5551-1		555119	211

DESCRIPTION	ITEM	SERIES	EAN 4002293	PAGE
Kitchen shears	5552-1		555218	211
Kitchen shears	5556		555607	211
Kitchen shears	5558		555805	211
Kitchen shears	5553		555300	212
Kitchen shears	5563		556307	212
Kitchen/Fish shears	5564		556406	212
Knife block	7235		72357	119
Knife block	7230	CRAFTER	723006	171
Knife block	7258		725802	172
Knife block	7260		726014	172
Knife block	7262		726205	172
Knife block	7266		726601	172
Knife block	7275-1		727523	173
Knife block	7277-1		727714	173
Knife block	7272-1		727219	173
Knife block	7267		726760	173
Knife block	7278-1		727813	173
Knife block	7237		723709	174
Knife block	7239		723907	174
Knife block	7240		724003	174
Knife block	7264		726403	174
Knife block	7265		726502	174
Knife block	7242		724201	175
Knife block	7243		724300	175
Knife block	7244		724409	175
Knife block	7246		724607	175
Knife block	7247		724706	175
Knife block	7248		724805	175
Knife block	7251		725109	176
Knife block	7253		725307	176
Knife block	7254		725406	176
Knife block	7255		725505	176
Knife block	7250		725000	176
Knife block	7252		725208	176
Knife block with 12 pcs.	9846	CLASSIC	984605	167
Knife block with 12 pcs.	9847	CLASSIC	984704	167
Knife block with 12 pcs.	9848	CLASSIC	984803	167
Knife block with 2 pcs.	9845	CRAFTER	984506	157
Knife block with 5 pcs.	9832	CLASSIC	983202	164
Knife block with 5 pcs.	9838-8	CLASSIC	983882	164
Knife block with 5 pcs.	9867	GOURMET	986715	168
Knife block with 5 pcs.	9835-8	GOURMET	983585	169
Knife block with 5 pcs.	9829	SILVERPOINT	982908	170
Knife block with 6 pcs.	9834	CRAFTER	983400	157
Knife block with 6 pcs.	9854	EPICURE	985404	156
Knife block with 6 pcs.	9856	EPICURE	985602	156
Knife block with 6 pcs.	9866	IKON	986609	158
Knife block with 6 pcs.	9876	CLASSIC IKON	987606	159
Knife block with 6 pcs.	9877	CL IKON creme	987705	163
Knife block with 6 pcs.	9831-2	GOURMET	983127	169
Knife block with 7 pcs.	9875	CLASSIC IKON	987507	160
Knife block with 7 pcs.	9878	CLASSIC IKON	987804	161

DESCRIPTION	ITEM	SERIES	EAN 4002293	PAGE
Knife block with 7 pcs.	9835	CLASSIC	983509	165
Knife block with 7 pcs.	9837	CLASSIC	983707	165
Knife block with 7 pcs.	9851	GRAND PRIX II	985107	168
Knife block with 7 pcs.	9864	SILVERPOINT	986401	170
Knife block with 8 pcs.	9880	CLASSIC IKON	988009	161
Knife block with 8 pcs.	9879	CL IKON creme	987903	162
Knife block with 8 pcs.	9882	CLASSIC IKON	988207	162
Knife block with 9 pcs.	9865	IKON	986500	159
Knife block with 9 pcs.	9873	CLASSIC IKON	987309	160
Knife block with 9 pcs.	9874	CL IKON creme	987408	163
Knife block with 9 pcs.	9842	CLASSIC	984209	166
Knife block with 9 pcs.	9843	CLASSIC	984308	166
Knife block with 9 pcs.	9844	CLASSIC	984407	166
Knife block, magnetic	7231		723105	171
Knife block, magnetic	7249		724904	172
Knife block, magnetic	7267		726700	173
Knife block, magnetic	7275-1		727523	173
Knife block, magnetic	7277-1		727714	173
Knife care oil	7905		790503	223
Knife roll (empty), for 6 pcs.	7370		737003	185
Knife roll (empty), for 6 pcs.	7372		737201	185
Knife roll (empty), for 9 pcs.	7371		737102	185
Knife roll (empty), for 9 pcs.	7374		737409	185
Knife set, 2 pcs.	9682	EPICURE	968209	140
Knife set, 2 pcs.	9276	CLASSIC IKON	927602	142
Knife set, 2 pcs.	9283	CLASSIC IKON	928302	142
Knife set, 2 pcs.	9606	CLASSIC IKON	960609	142
Knife set, 2 pcs.	9280	CLASSIC	928005	144
Knife set, 2 pcs.	9755	CLASSIC	975504	144
Knife set, 2 pcs.	9655	GRAND PRIX II	965505	147
Knife set, 2 pcs.	9275	GRAND PRIX II	927503	147
Knife set, 2 pcs.	9281	GOURMET	928104	148
Knife set, 2 pcs.	9261	GOURMET	926100	149
Knife set, 2 pcs.	9279	SILVERPOINT	927909	152
Knife set, 2 pcs.	9811	SILVERPOINT	981109	152
Knife set, 2 pcs.	9282		928203	153
Knife set, 2 pcs.	9284		928401	153
Knife set, 3 pcs.	9601	CLASSIC IKON	960104	141
Knife set, 3 pcs.	9600	IKON	960005	141
Knife set, 3 pcs.	9601-0	CL IKON creme	260105	143
Knife set, 3 pcs.	9608	CLASSIC	960807	144
Knife set, 3 pcs.	9660	CLASSIC	966007	144
Knife set, 3 pcs.	9285	CLASSIC	928500	146
Knife set, 3 pcs.	9605	GRAND PRIX II	960500	147
Knife set, 3 pcs.	9675	GOURMET	967509	148
Knife set, 3 pcs.	8010	GOURMET	801001	149
Knife set, 3 pcs.	9288	GOURMET	928807	150
Knife set, 3 pcs.	9815	SILVERPOINT	981505	151
Knife set, 3 pcs.	9814	SILVERPOINT	981406	151
Knife sharpener	4343		434308	201
Knife sharpener	4347		434704	201
Knife sharpener	4348		434803	201

DESCRIPTION	ITEM	SERIES	EAN 4002293	PAGE
Larding needle	4382		438207	219
Larding needle	4380		438009	223
Lemon zester	3086		308609	219
Lober forks, 4 pcs.	3320		332000	222
Lober prongs	5864		586403	222
Long slicer	4522/26	CLASSIC	452265	88
Machete	3499/18	URBAN FARMER	349909	34
Magnetic block	7231		723105	171
Magnetic block with 6 pcs.	9884-2		988429	155
Magnetic holder	7221/30		722115	178
Magnetic holder	7221/50		572215	178
Magnetic holder	7222/30		372228	178
Magnetic holder	7222/50		572222	178
Magnetic holder	7223/30		722313	178
Magnetic holder	7223/45		722320	178
Magnetic holder	7224/40		722405	178
Magnetic holder	7225/30		722511	179
Magnetic holder	7225/45		722528	179
Magnetic holder	7226/35		722610	179
Magnetic holder	7226/50		722627	179
Magnetic holder	7227/30		722702	179
Magnetic holder	7227/45		722719	179
Magnetic holder	7228/35		722818	179
Magnetic holder	7228/50		722825	179
Meat tenderizer	4702		470207	221
Melon baller	4241		424101	220
Melon baller	4240/1.5		424026	220
Melon baller	4240/1.8		424033	220
Melon baller	4240/2.2		424040	220
Melon baller	4240/2.5		424057	220
Melon baller	4240/1.0		424019	220
Melon baller	4240/3.0		424064	220
Mincing board	7281		728100	137
Mincing knife	4730		473000	137
Mincing knife	4731		473109	137
Mincing knife	4732		473208	137
Mincing knife	4734		473406	137
Mincing knife	4735		473505	137
Mincing knife	4736		473604	137
Mincing knife	4740		474007	137
Mincing set	9881		988108	137
Nakiri	4187/17	CLASSIC IKON	418742	61
Nakiri	4193	CLASSIC	419305	93
Orange peeler	3064		306407	219
Oyster opener	4281		428109	221
Oyster opener	4282		428208	221
Oyster opener	4284		428406	221
Paring knife	3765/09	CRAFTER	037653	25
Paring knife	3466/10	URBAN FARMER	346625	33
Paring knife	3966/09	EPICURE	396637	41
Paring knife	3966/12	EPICURE	396675	41
Paring knife	4984	IKON	498409	49

DESCRIPTION	ITEM	SERIES	EAN 4002293	PAGE
Paring knife	4986/09	IKON	498614	49
Paring knife	4006	CLASSIC IKON	400600	59
Paring knife	4086/09	CLASSIC IKON	408613	59
Paring knife	4006-0	CL IKON creme	200606	71
Paring knife	4086-0/09	CL IKON creme	208619	71
Paring knife	4000	CLASSIC	400006	81
Paring knife	4066/09	CLASSIC	406619	82
Paring knife	4066/10	CLASSIC	406626	82
Paring knife	4065/09	CLASSIC	406510	92
Paring knife	4015	GRAND PRIX II	401508	101
Paring knife	4040/09	GRAND PRIX II	404011	101
Paring knife	4010/08	GOURMET	401027	111
Paring knife	4010/09	GOURMET	401034	111
Paring knife	4011	GOURMET	401102	112
Paring knife	4022	GOURMET	402208	112
Paring knife	4042	GOURMET	404202	112
Paring knife	4013	SILVERPOINT	401300	125
Paring knife	4043	SILVERPOINT	404301	125
Paring knife	4052	SILVERPOINT	405209	126
Paring knife	4023	SILVERPOINT	402307	126
Paring knife set, 3 pcs.	9727	GOURMET	972701	148
Paring knife set, 3 pcs.	9352	SILVERPOINT	935201	152
Peeling knife	4920	IKON	492001	49
Peeling knife	4020	CLASSIC IKON	402000	59
Peeling knife	4020-0	CL IKON creme	202006	71
Peeling knife	4062	CLASSIC	406206	81
Peeling knife	4025	GRAND PRIX II	402505	101
Peeling knife	4034	GOURMET	403403	111
Peeling knife	4033	SILVERPOINT	403304	125
Pizza cutter	4274		427409	220
Plating tongs	7725-1		177250	222
Polishing steel	4475/32		447506	195
Polishing steel	4476/32		447605	195
Potato peeler	4072		407203	219
Potato peeling fork	4250		425009	219
Poultry shears	5501		550107	210
Poultry shears	5505		550503	210
Poultry shears	5508		550800	210
Poultry shears	5509		550909	210
Poultry shears	5512		551203	210
Pruning knife	3400/08	URBAN FARMER	340012	33
Replacement set	7918-1		791814	193
Replacement wire for 3112	7920		792002	223
Reshaping stone	4454		445403	200
Roast beef slicer	3922/23	EPICURE	392257	42
Roast beef slicer	4511	GOURMET	451107	117
Roast beef slicer	4513/26	GOURMET	451312	117
Roast beef slicer	4513/32	GOURMET	451329	117
Roast beef slicer	4513/36	GOURMET	451343	117
Roast beef slicer	4515/32	GOURMET	451510	117
Roast beef slicer	4515/36	GOURMET	451527	117
Salmon slicer	4546	CLASSIC IKON	454603	64

DESCRIPTION	ITEM	SERIES	EAN 4002293	PAGE
Salmon slicer	4542	CLASSIC	454207	91
Salmon slicer	4543	CLASSIC	454306	91
Salmon slicer	4540	GOURMET	454009	116
Salmon slicer	4541	GOURMET	454108	116
Salmon slicer	4544	SILVERPOINT	454405	129
Santoku	3783/17	CRAFTER	437835	26
Santoku	3483/17	URBAN FARMER	348353	34
Santoku	4972	IKON	497204	51
Santoku	4976	IKON	497600	51
Santoku	4172	CLASSIC IKON	417202	63
Santoku	4176	CLASSIC IKON	417608	63
Santoku	4172-0	CL IKON creme	217208	73
Santoku	4176-0	CL IKON creme	217604	73
Santoku	4181	CLASSIC	418100	93
Santoku	4182	CLASSIC	418209	93
Santoku	4183	CLASSIC	418308	93
Santoku	4173	GRAND PRIX II	417301	103
Santoku	4174	GRAND PRIX II	417400	103
Santoku	4175	GRAND PRIX II	417509	103
Santoku	4186	GOURMET	418605	119
Santoku	4188	GOURMET	418803	119
Santoku	4180	SILVERPOINT	418001	129
Santoku	4184	SILVERPOINT	418414	129
Santoku	3983	EPICURE	398327	43
Sausage knife	3710	CRAFTER	37103	25
Sausage knife	3911	EPICURE	391120	41
Sausage knife	4926	IKON	492605	50
Sausage knife	4126	CLASSIC IKON	412603	60
Sausage knife	4126-0	CL IKON creme	212609	72
Sausage knife	4110	CLASSIC	411002	82
Sausage knife	4106	GRAND PRIX II	410609	102
Sausage knife	4107	GOURMET	410708	113
Screw and nut for 4082	7941		794105	223
Screw and nut for 5556	7965		796505	223
Screws and blade for 4075	7939		793900	223
Serrated slicer	4523/23	CLASSIC	452326	89
Serrated utility knife	3410/14	URBAN FARMER	341019	33
Sharpening guide „Slider“	4349		434902	200
Sharpening steel	4468-0	CL IKON creme	246802	196
Sharpening steel	4472	CLASSIC	447209	196
Sharpening steel	4468	CLASSIC IKON	446806	196
Sharpening steel	4477	GRAND PRIX II	447704	196
Sharpening steel	4968	IKON	496801	196
Sharpening steel	4462		446202	197
Sharpening steel	4473		447308	197
Sharpening steel	4460/23		446028	197
Sharpening steel	4463/18		446318	197
Sharpening steel	4463/23		446325	197
Sharpening steel	4465/23		446516	197
Sharpening steel	4471		447100	198
Sharpening steel	4470/26		447018	198
Sharpening steel	4470/29		447025	198

DESCRIPTION	ITEM	SERIES	EAN 4002293	PAGE
Sharpening steel	4470/32		447032	198
Sharpening steel	4474/26		447414	198
Sharpening steel	4474/32		447421	198
Shutter and screw for 5512	7964		796406	223
Slicer	4114/20	GOURMET	411415	116
Slicer	4510/16	SILVERPOINT	451022	129
Slicer	4510/20	SILVERPOINT	451008	129
Spare parts for 4348	7923		792309	223
Spatula	4430/15		443010	216
Spatula	4430/20		443027	216
Spatula	4430/25		443034	216
Spatula	4430/30		443041	216
Spatula	4435		443508	217
Spatula	4436		443607	217
Spatula	4437		443713	217
Spatula	4438		443805	217
Spatula	4421		442105	218
Spatula	4425		442501	218
Spatula	4426		442617	218
Spatula	4420/20		442044	218
Spatula	4420/25		442051	218
Spring for 5501, 5502 and 5505	7960		796017	223
Spring for 5508	7962		796208	223
Spring for 5512	7959		795904	223
Steak knife	3968	EPICURE	396835	41
Steak knife	4988	IKON	498805	50
Steak knife	4096	CLASSIC IKON	409603	60
Steak knife	4096-0	CL IKON creme	209609	72
Steak knife	4048	GRAND PRIX II	404806	102
Steak knife	4050	GOURMET	405001	113
Steak knife	4041	SILVERPOINT	404103	126
Steak knife set, 4 pcs.	9738	CRAFTER	097381	140
Steak knife set, 4 pcs.	9401	URBAN FARMER	940106	140
Steak knife set, 4 pcs.	9668	EPICURE	966809	140
Steak knife set, 4 pcs.	9716	CLASSIC IKON	971605	141
Steak knife set, 4 pcs.	9706	IKON	970608	141
Steak knife set, 4 pcs.	9716-0	CL IKON creme	271606	143
Steak knife set, 4 pcs.	9731	CLASSIC	973104	143
Steak knife set, 4 pcs.	9625	GRAND PRIX II	962504	146
Steak knife set, 4 pcs.	9729	GOURMET	972909	148
Steak knife set, 4 pcs.	9634	SILVERPOINT	963402	151
Steak knife set, 6 pcs.	9730	CLASSIC	973005	143
Steak knife set, 6 pcs.	9728	GOURMET	972800	148
Steak set, 4 pcs.	9534		953403	139
Straight meat fork	4414-0/16	CL IKON creme	241425	214
Straight meat fork	4410/16	CLASSIC	441030	214
Straight meat fork	4410/18	CLASSIC	441047	214
Straight meat fork	4410/20	CLASSIC	441054	214
Straight meat fork	4414/16	CLASSIC IKON	441429	214
Straight meat fork	4417	GRAND PRIX II	441733	214
Straight meat fork	4914/16	IKON	491424	214
Straight meat fork	4413/18	CLASSIC	441344	215

DESCRIPTION	ITEM	SERIES	EAN 4002293	PAGE
Super slicer	3607/26	AEON	103310	19 NEW
Super slicer	3732/26	CRAFTER	104416	27 NEW
Super slicer	4516	CLASSIC IKON	451602	61
Super slicer	4532	CLASSIC	453200	90
Super slicer	4519	GOURMET	451916	116
Swivel potato peeler	4075		407500	219
Tomato knife	4136	CLASSIC IKON	413600	60
Tomato knife	4109	CLASSIC	410906	82
Tomato knife	4105	GOURMET	410500	113
Tool Basket	7410	URBAN FARMER	741000	171
Tool Basket, 4 pcs.	9480	URBAN FARMER	948003	158
Traveler set, 6 pcs.	9789	CLASSIC	978901	146
Traveler set, 6 pcs.	9789-1	GOURMET	978918	150
Trimming knife	4002	CLASSIC	400204	81
Trussing needle	4385		438504	223
Turner	4433		443300	216
Turner	4434		443409	216
Turner	4424		442402	218
Upgrade set	7918		791807	193
Utility knife	4986/12	IKON	498638	49
Utility knife	4906/16	IKON	490625	50
Utility knife	4086/12	CLASSIC IKON	408637	59
Utility knife	4506/16	CLASSIC IKON	450629	63
Utility knife	4086-0/12	CL IKON creme	208626	71
Utility knife	4506-0/16	CL IKON creme	250625	72
Utility knife	4066/12	CLASSIC	406633	82
Utility knife	4522/14	CLASSIC	452210	88
Utility knife	4522/16	CLASSIC	452227	88
Utility knife	4522/18	CLASSIC	452234	88
Utility knife	4040/12	GRAND PRIX II	404035	101
Utility knife	4525/16	GRAND PRIX II	452524	102
Utility knife	4045	GOURMET	404509	112
Utility knife	4060	GOURMET	406008	112
Utility knife	4114/16	GOURMET	411408	116
Utility knife	4051	SILVERPOINT	405100	126
Whetstone	4450		445007	199
Whetstone	4451		445106	199
Whetstone	4453		445304	199
Whetstone	4452		445205	199
Wide cook's knife	4584/20	CLASSIC	458410	85
Wide cook's knife	4584/26	CLASSIC	458427	85
Wood insert for chopping board 7292	7992		799209	223

PLEASE NOTE: For production reasons, the dimensions stated in this catalogue can differ slightly. We reserve the right to make technical changes.



Each individual knife from WÜSTHOF stands for uncompromising quality

IN WÜSTHOF QUALITY ASSURANCE, ONLY PERFECTION COUNTS

In this way, you can be certain that each knife may only leave our factory after it has proven 100% sharpness in the cutting test and demonstrated its excellent quality in the final checks. Guaranteed!

During production all knives go through quality controls again and again – in the Classic Series, for example, there are a total of 22 quality control points. This includes optical measuring stations which measure the blades within seconds at 1000 check-points, the uncompromising blade check, the precise check of cutting geometry with the most modern laser technology and the conclusive cutting test of each individual knife. If the strict quality demands are not met, the knife will not be allowed to carry on to the next process.

In quality control, as in production, we place our trust in the perfect symbiosis of man and machine. While computer-controlled, technical solutions are accurate and cannot be swayed, only a person with their sensory abilities can give the final approval for the perfect quality of a WÜSTHOF knife.



WÜSTHOF

Made in Solingen

WÜSTHOF GmbH
Kronprinzenstraße 49
42655 Solingen

WUSTHOF.COM