

Exquisite

PRODUCT CATALOGUE 2024



Company Overview

Exquisite Marketing Australia Pty. Ltd. was established in 2004 as an importer and distributor of commercial refrigeration products. At Exquisite Marketing Australia we have a strong team environment and provide all our clients with a reliable and highly valued service.

Since the start of our business, our company has grown each year, thanks to support from our customers for our quality products and services. We now have a commercial refrigeration range that fit whole commercial kitchen needs, display refrigeration for your store, medical refrigeration range as well as other refrigeration products.

Our objective is to provide our clients with high quality equipment that performs exceptionally well in diverse climate supported by reliable service network throughout the Australia. Exquisite Marketing Australia pride ourselves on providing trustworthy services, delivered by our dedicated staff who have the experience and skills to advise you on all your refrigeration requirements.

Along with our company commitment towards environmentally friendly and sustainable direction, we introduced new gas on our product range. We are using R290 and R600a gas, ozone friendly with better thermodynamic qualities that translates into lower energy consumption for lower running cost. We have converted most of our product range with new gas in support to more sustainable future to our planet.



Exquisite

Contents

Commercial Kitchen



Underbench storage refrigerators and freezers	5-13
Upright storage refrigerators and freezers	14-18
Food preparation refrigerators	19-20
Counter top food preparation refrigerators	21
Storage chest freezers - stainless steel top	22

Display Cabinets



Counter top display refrigerators	25
Upright display refrigerators	26-31
Supermarket display refrigerators	32
Backbar display refrigerators	33-37
Cake display refrigerators	38-41
Counter top cake display refrigerators	42-43
Ambient cake display	44-45

Display Freezers



Curved glass display freezers	47
Flat glass display freezers	48
Ice cream scooping freezers	49
Gelato freezer	50
Supermarket Island freezers	51

Vaccine Refrigerators



Vaccine refrigerators	53-54
-----------------------	-------

Commercial Kitchen



Underbench Storage Refrigerators with Solid Door

Features:

- Self closing stainless steel doors with integrated handles
- Digital controller and digital temperature display
- Dynamic fan forced cooling system with automatic defrosting
- Shelf to fit gastronorm pan size GN1/1
- Stainless steel finish exterior and interior
- Frequency/voltage: 50Hz/220-240 V
- Plastic coated steel shelves
- Lockable engine compartment
- Refrigerant: R290
- Lockable castor wheels
- Ambient temperatures +16°C to +43°C



USC260H

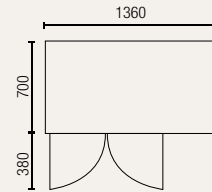
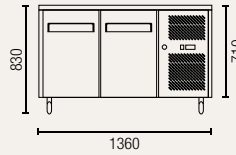

Allow min. 100mm clearance for installation, all vents must be left clear

Gross volume: 314 L

Exterior dimensions in mm: 1360w x 700d x 830h

Number of adjustable shelves: 2

Temperature set range: -2°C to +8°C

Gross/net weight: 119/102 kg

Energy consumption in 24h: 2.2 kWh

USC400H

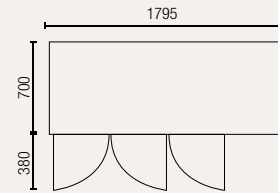
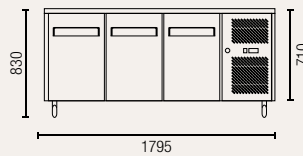

Allow min. 100mm clearance for installation, all vents must be left clear

Gross volume: 465 L

Exterior dimensions in mm: 1795w x 700d x 830h

Number of adjustable shelves: 3

Temperature set range: -2°C to +8°C

Gross/net weight: 140/121 kg

Energy consumption in 24h: 3.1 kWh

USC550H

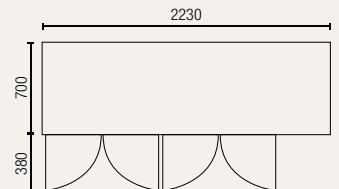
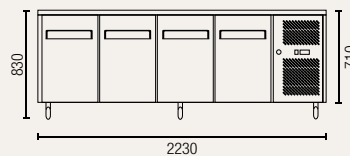

Allow min. 100mm clearance for installation, all vents must be left clear

Gross volume: 616 L

Exterior dimensions in mm: 2230w x 700d x 830h

Number of adjustable shelves: 4

Temperature set range: -2°C to +8°C

Gross/net weight: 170/150 kg

Energy consumption in 24h: 4.7 kWh

Underbench Storage Refrigerators with Solid Door - Slimline

Features:

- Self closing stainless steel doors with integrated handles
- Digital controller and digital temperature display
- Dynamic fan forced cooling system with automatic defrosting
- Stainless steel finish exterior and interior
- Frequency/voltage: 50Hz/220-240 V
- Plastic coated steel shelves
- Lockable engine compartment
- Refrigerant: R290
- Lockable castor wheels
- Ambient temperatures +16°C to +43°C



SSC260H

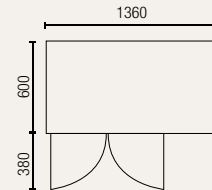
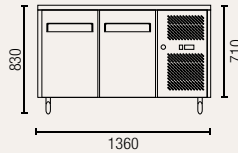

Allow min. 100mm clearance for installation, all vents must be left clear

Gross volume: 260 L

Exterior dimensions in mm: 1360w x 600d x 830h

Number of adjustable shelves: 2

Temperature set range: -2°C to +8°C

Gross/net weight: 92/83 kg

Energy consumption in 24h: 2.2 kWh

SSC400H

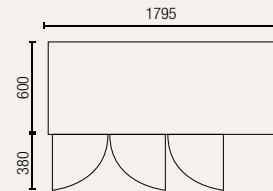
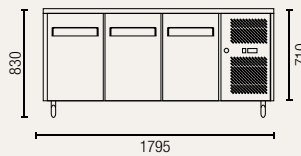

Allow min. 100mm clearance for installation, all vents must be left clear

Gross volume: 386 L

Exterior dimensions in mm: 1795w x 600d x 830h

Number of adjustable shelves: 3

Temperature set range: -2°C to +8°C

Gross/net weight: 130/105 kg

Energy consumption in 24h: 3.1 kWh

SSC550H

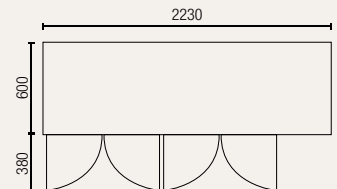
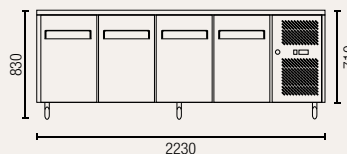

Allow min. 100mm clearance for installation, all vents must be left clear

Gross volume: 511 L

Exterior dimensions in mm: 2230w x 600d x 830h

Number of adjustable shelves: 4

Temperature set range: -2°C to +8°C

Gross/net weight: 156/121 kg

Energy consumption in 24h: 4.7 kWh

Underbench Storage Refrigerators with Glass Door

Features:

- Self closing glass doors with handles
- Digital controller and digital temperature display
- Dynamic fan forced cooling system with automatic defrosting
- Continuous shelf for maximum use of space
- Stainless steel finish exterior and interior
- Frequency/voltage: 50Hz/220-240 V
- Plastic coated steel shelves
- Lockable engine compartment
- Refrigerant: R290
- Lockable castor wheels
- Ambient temperatures +16°C to +43°C



USC260G



Continuous shelf for maximum use of space

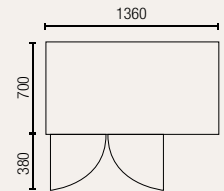
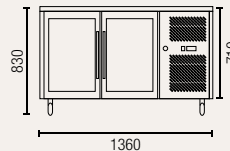

Allow min. 100mm clearance for installation, all vents must be left clear

Gross volume: 314 L

Exterior dimensions in mm: 1360w x 700d x 830h

Number of adjustable shelves: 2

Temperature set range: -2°C to +8°C

Gross/net weight: 125/108 kg

Energy consumption in 24h: 2.2 kWh

USC400G

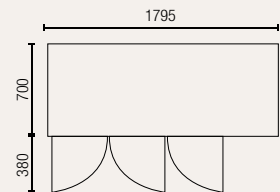
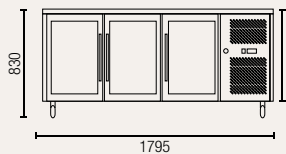

Continuous shelf for maximum use of space



Allow min. 100mm clearance for installation, all vents must be left clear

Gross volume: 465 L

Exterior dimensions in mm: 1795w x 700d x 830h

Number of adjustable shelves: 3

Temperature set range: -2°C to +8°C

Gross/net weight: 153/134 kg

Energy consumption in 24h: 3.1 kWh

USC550G

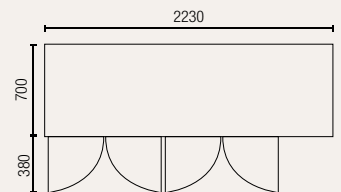
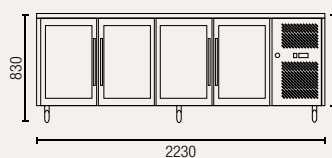

Continuous shelf for maximum use of space



Allow min. 100mm clearance for installation, all vents must be left clear

Gross volume: 616 L

Exterior dimensions in mm: 2230w x 700d x 830h

Number of adjustable shelves: 4

Temperature set range: -2°C to +8°C

Gross/net weight: 177/158 kg

Energy consumption in 24h: 4.7 kWh

Underbench Storage Refrigerators with Glass Door - Slimline

Features:

- Self closing glass doors with integrated handles
- Digital controller and digital temperature display
- Dynamic fan forced cooling system with automatic defrosting
- Continuous shelf for maximum use of space
- Stainless steel finish exterior and interior
- Frequency/voltage: 50Hz/220-240 V
- Plastic coated steel shelves
- Lockable engine compartment
- Refrigerant: R290
- Lockable castor wheels
- Ambient temperatures +16°C to +43°C



SSC260G



Continuous shelf for maximum use of space

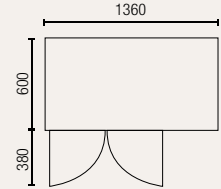
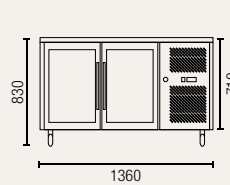

Allow min. 100mm clearance for installation, all vents must be left clear

Gross volume: 260 L

Exterior dimensions in mm: 1360w x 600d x 830h

Number of adjustable shelves: 2

Temperature set range: -2°C to +8°C

Gross/net weight: 120/103 kg

Energy consumption in 24h: 2.2 kWh

SSC400G

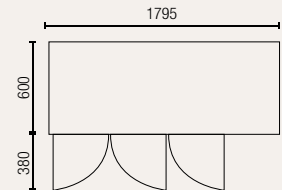
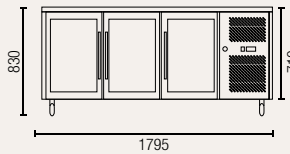

Continuous shelf for maximum use of space



Allow min. 100mm clearance for installation, all vents must be left clear

Gross volume: 386 L

Exterior dimensions in mm: 1795w x 600d x 830h

Number of adjustable shelves: 3

Temperature set range: -2°C to +8°C

Gross/net weight: 148/129 kg

Energy consumption in 24h: 3.1 kWh

SSC550G

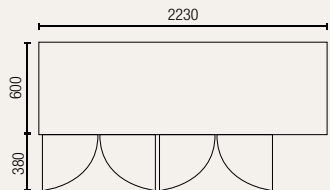
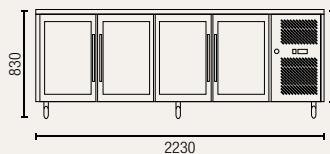

Continuous shelf for maximum use of space



Allow min. 100mm clearance for installation, all vents must be left clear

Gross volume: 511 L

Exterior dimensions in mm: 2230w x 600d x 830h

Number of adjustable shelves: 4

Temperature set range: -2°C to +8°C

Gross/net weight: 172/153 kg

Energy consumption in 24h: 4.7 kWh

Underbench Storage Freezers with Solid Door

Features:

- Self closing stainless steel doors with integrated handles
- Digital controller and digital temperature display
- Dynamic fan forced cooling system with automatic defrosting
- Shelf to fit gastronorm pan size GN1/1
- Stainless steel finish exterior and interior
- Frequency/voltage: 50Hz/220-240 V
- Plastic coated steel shelves
- Lockable engine compartment
- Refrigerant: R290
- Lockable castor wheels
- Ambient temperatures +16°C to +43°C



USF260H

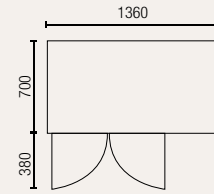
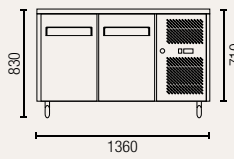

Allow min. 100mm clearance for installation, all vents must be left clear

Gross volume: 314 L

Exterior dimensions in mm: 1360w x 700d x 830h

Number of adjustable shelves: 2

Temperature set range: -18°C to -22°C

Gross/net weight: 124/107 kg

Energy consumption in 24h: 7.8 kWh

USF400H

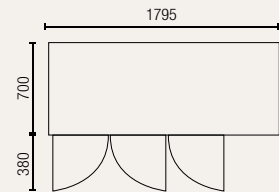
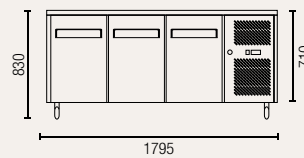

Allow min. 100mm clearance for installation, all vents must be left clear

Gross volume: 465 L

Exterior dimensions in mm: 1795w x 700d x 830h

Number of adjustable shelves: 3

Temperature set range: -18°C to -22°C

Gross/net weight: 165/146 kg

Energy consumption in 24h: 8.2 kWh

Underbench Storage Freezers with Solid Door - Slimline

Features:

- Self closing stainless steel doors with integrated handles
- Digital controller and digital temperature display
- Dynamic fan forced cooling system with automatic defrosting
- Stainless steel finish exterior and interior
- Frequency/voltage: 50Hz/220-240 V
- Plastic coated steel shelves
- Lockable engine compartment
- Refrigerant: R290
- Lockable castor wheels
- Ambient temperatures +16°C to +43°C



SSF260H

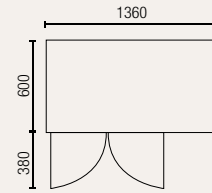
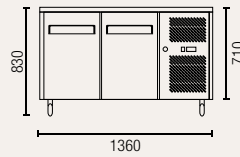

Allow min. 100mm clearance for installation, all vents must be left clear

Gross volume: 260 L

Exterior dimensions in mm: 1360w x 600d x 830h

Number of adjustable shelves: 2

Temperature set range: -18°C to -22°C

Gross/net weight: 124/107 kg

Energy consumption in 24h: 7.8 kWh

SSF400H

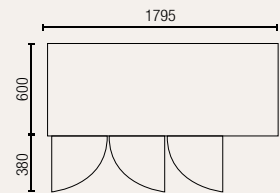
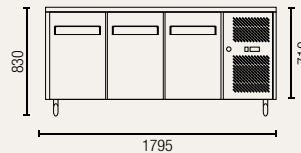

Allow min. 100mm clearance for installation, all vents must be left clear

Gross volume: 386 L

Exterior dimensions in mm: 1795w x 600d x 830h

Number of adjustable shelves: 3

Temperature set range: -18°C to -22°C

Gross/net weight: 165/146 kg

Energy consumption in 24h: 9.2 kWh

Single Door Underbench Storage Refrigerators

Features:

- Lockable door with handles
- Static cooling system with manual defrosting
- Adjustable feet with roller at the back
- Frequency/voltage: 50Hz/220-240 V
- Digital controller and digital temperature display
- Plastic coated steel shelves
- Refrigerant: R600a
- Insulation thickness: 45 mm



MC210H

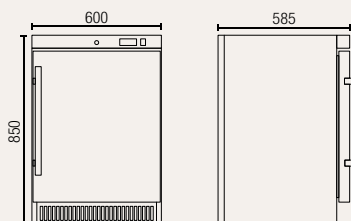

⚠ Allow min. 100mm clearance for installation, all vents must be left clear

Gross volume: 130 L

Exterior dimensions in mm: 600w x 585d x 850h

Number of adjustable shelves: 3

Energy consumption in 24h: 0.94 kWh

Temperature set range: -2°C to +10°C

Gross/net weight: 49/41 kg

Door material: stainless steel

Ambient temperatures: 30°C

MC210G

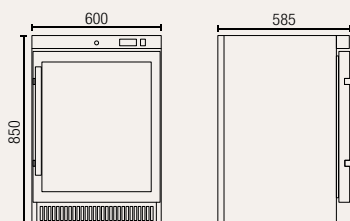

⚠ Allow min. 100mm clearance for installation, all vents must be left clear

Gross volume: 136 L

Exterior dimensions in mm: 600w x 585d x 850h

Number of adjustable shelves: 3

Energy consumption in 24h: 1.82 kWh

Temperature set range: 0°C to +10°C

Gross/net weight: 52/44 kg

Door material: glass

Ambient temperatures: 25°C

Single Door Underbench Storage Freezers

Features:

- Lockable door with handles
- Static cooling system with manual defrosting
- Adjustable feet with roller at the back
- Frequency/voltage: 50Hz/220-240 V
- Digital controller and digital temperature display
- Plastic coated steel shelves
- Refrigerant: R290
- Insulation thickness: 59 mm



MF210H

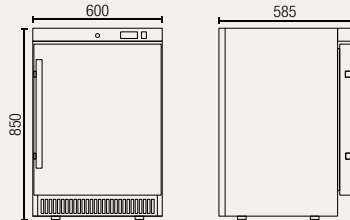

Allow min. 100mm clearance for installation, all vents must be left clear

Gross volume: 108 L

Exterior dimensions in mm: 600w x 585d x 850h

Number of shelves: 3

Energy consumption in 24h: 1.22 kWh

Temperature set range: -18°C to -25°C

Gross/net weight: 52/44 kg

Door material: stainless steel

Ambient temperatures: 30°C

MF210G

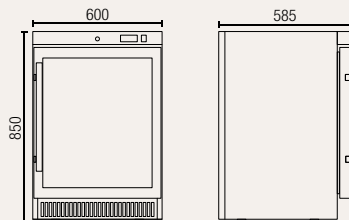

Allow min. 100mm clearance for installation, all vents must be left clear

Gross volume: 114 L

Exterior dimensions in mm: 600w x 585d x 850h

Number of shelves: 3

Energy consumption in 24h: 2.14 kWh

Temperature set range: -18°C to -22°C

Gross/net weight: 58/50 kg

Door material: glass

Ambient temperatures: 25°C

Single Door Underbench Storage Refrigerators

Features:

- Lockable door with handles
- Digital controller and digital temperature display
- Adjustable feet
- Frequency/voltage: 50Hz/220-240 V
- Plastic coated steel shelves
- Refrigerant: R134a
- Ambient temperatures +16°C to +32°C



MC200H



RUN OUT MODEL
Limited Stock

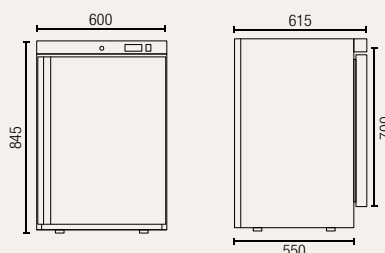

Allow min. 100mm clearance for installation, all vents must be left clear

Gross volume: 140 L

Exterior dimensions in mm: 600w x 615d x 845h

Number of adjustable shelves: 3

Cooling system: static, fan assisted

Defrost system: manual

Temperature set range: 0°C to +10°C

Gross/net weight: 55/45 kg

Door material: stainless steel

Energy consumption in 24h: 2 kWh

MC200G



RUN OUT MODEL
Limited Stock

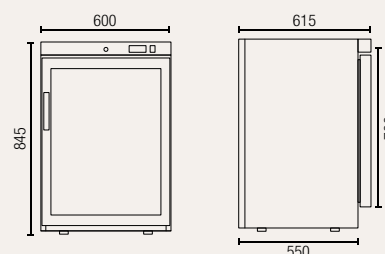

Allow min. 100mm clearance for installation, all vents must be left clear

Gross volume: 140 L

Exterior dimensions in mm: 600w x 615d x 845h

Number of adjustable shelves: 3

Cooling system: static, fan assisted

Defrost system: manual

Temperature set range: 0°C to +10°C

Gross/net weight: 55/45 kg

Door material: glass

Energy consumption in 24h: 2 kWh

Upright Storage Refrigerators with Solid Door

Features:

- Lockable self closing stainless steel doors with integrated handles
- Digital controller and digital temperature display
- Dynamic fan forced cooling system with automatic defrosting
- Shelf to fit gastronorm pan size GN2/1
- Frequency/voltage: 50Hz/220-240 V
- Stainless steel finish exterior and interior
- Plastic coated steel shelves
- Refrigerant: R290
- Lockable castor wheels
- Ambient temperatures from +16°C to +43°C



GSC650H

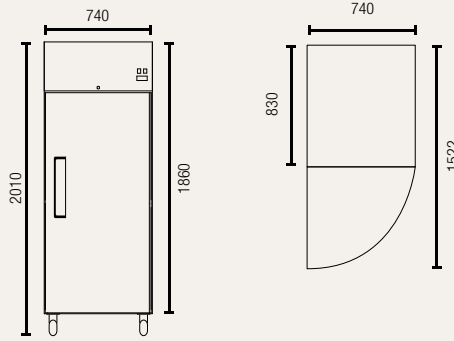

 Allow min. 100mm clearance for installation, all vents must be left clear

Gross volume: 685 L

Exterior dimensions in mm: 740w x 830d x 2010h

Number of adjustable shelves: 3

Temperature set range: -2°C to +8°C

Gross/net weight: 136/121 kg

Energy consumption in 24h: 2.78 kWh

GSC1410H

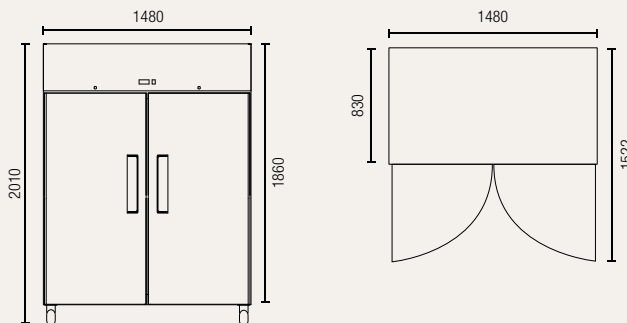

 Allow min. 100mm clearance for installation, all vents must be left clear

Gross volume: 1476 L

Exterior dimensions in mm: 1480w x 830d x 2010h

Number of adjustable shelves: 6

Temperature set range: -2°C to +8°C

Gross/net weight: 213/188 kg

Energy consumption in 24h: 4.15 kWh

Upright Storage Refrigerators with Split Solid Door

Features:

- Lockable self closing stainless steel doors with integrated handles
- Digital controller and digital temperature display
- Dynamic fan forced cooling system with automatic defrosting
- Shelf to fit gastronorm pan size GN2/1
- Frequency/voltage: 50Hz/220-240 V
- Stainless steel finish exterior and interior
- Plastic coated steel shelves
- Refrigerant: R290
- Lockable castor wheels
- Ambient temperatures from +16°C to +43°C



GSC652H

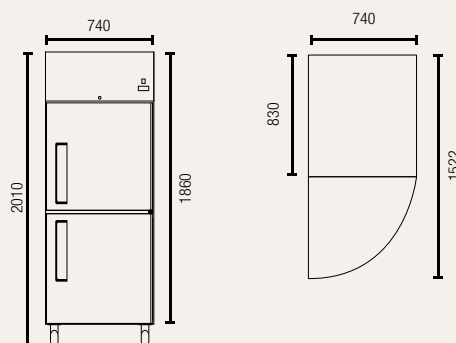

 Allow min. 100mm clearance for installation, all vents must be left clear

Gross volume: 685 L

Exterior dimensions in mm: 740w x 830d x 2010h

Number of adjustable shelves: 3

Temperature set range: -2°C to +8°C

Gross/net weight: 136/121 kg

Energy consumption in 24h: 3.1 kWh

GSC1412H

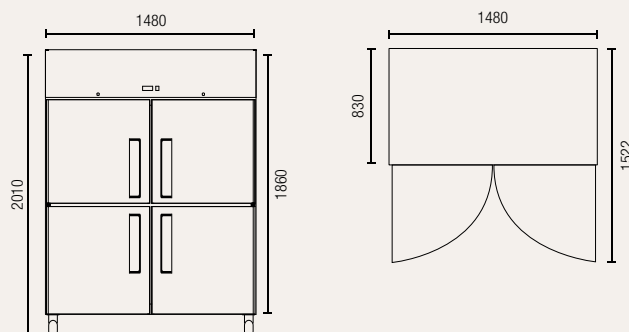

 Allow min. 100mm clearance for installation, all vents must be left clear

Gross volume: 1476 L

Exterior dimensions in mm: 1480w x 830d x 2010h

Number of adjustable shelves: 6

Temperature set range: -2°C to +8°C

Gross/net weight: 213/188 kg

Energy consumption in 24h: 4.3 kWh

Upright Storage Refrigerators with Glass Door

Features:

- Lockable self closing glass doors with handles
- Digital controller and digital temperature display
- Dynamic fan forced cooling system with automatic defrosting
- Shelf to fit gastronom pan size GN2/1
- Frequency/voltage: 50Hz/220-240 V
- Stainless steel finish exterior and interior
- Plastic coated steel shelves
- Refrigerant: R290
- Lockable castor wheels
- Ambient temperatures from +16°C to +43°C



GSC650G

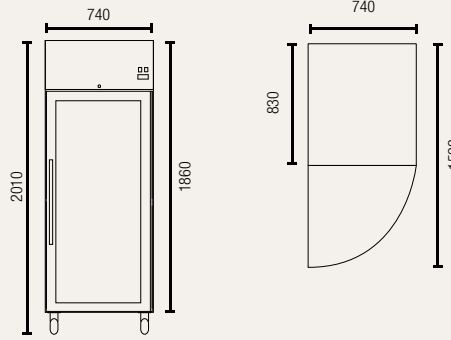

Allow min. 100mm clearance for installation, all vents must be left clear

Gross volume: 685 L

Exterior dimensions in mm: 740w x 830d x 2010h

Number of adjustable shelves: 3

Temperature set range: -2°C to +8°C

Gross/net weight: 147/132 kg

Energy consumption in 24h: 3.1 kWh

GSC1410G



Bridge between shelves for maximum use of space

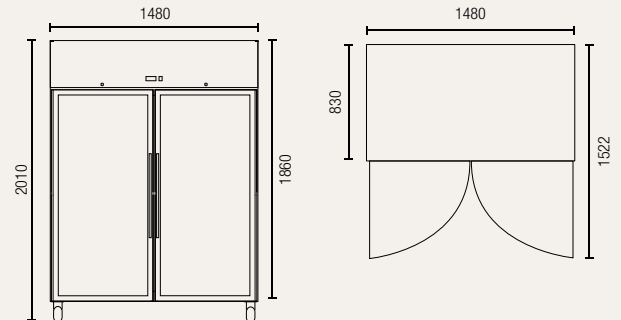

Allow min. 100mm clearance for installation, all vents must be left clear

Gross volume: 1476 L

Exterior dimensions in mm: 1480w x 830d x 2010h

Number of adjustable shelves: 6

Temperature set range: -2°C to +8°C

Gross/net weight: 233/208 kg

Energy consumption in 24h: 4.3 kWh

Upright Storage Freezers with Solid Door

Features:

- Lockable self closing stainless steel doors with integrated handles
- Digital controller and digital temperature display
- Dynamic fan forced cooling system with automatic defrosting
- Shelf to fit gastronorm pan size GN2/1
- Frequency/voltage: 50Hz/220-240 V
- Stainless steel finish exterior and interior
- Plastic coated steel shelves
- Refrigerant: R290
- Lockable castor wheels
- Ambient temperatures from +16°C to +43°C



GSF650H

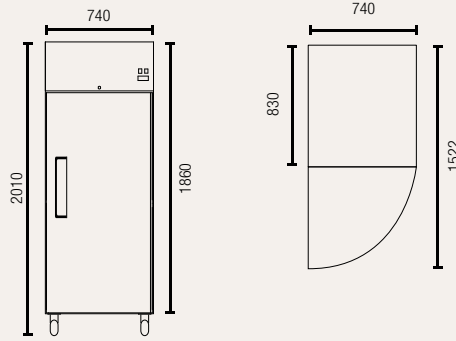

⚠ Allow min. 100mm clearance for installation, all vents must be left clear

Gross volume: 685 L

Exterior dimensions in mm: 740w x 830d x 2010h

Number of adjustable shelves: 3

Temperature set range: -18°C to -22°C

Gross/net weight: 141/126 kg

Energy consumption in 24h: 6.44 kWh

GSF1410H

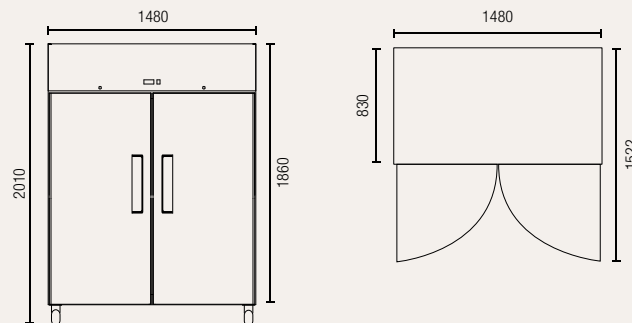

⚠ Allow min. 100mm clearance for installation, all vents must be left clear

Gross volume: 1476 L

Exterior dimensions in mm: 1480w x 830d x 2010h

Number of adjustable shelves: 6

Temperature set range: -18°C to -22°C

Gross/net weight: 226/201 kg

Energy consumption in 24h: 10 kWh

Upright Storage Freezers with Split Solid Door

Features:

- Lockable self closing stainless steel doors with integrated handles
- Digital controller and digital temperature display
- Dynamic fan forced cooling system with automatic defrosting
- Shelf to fit gastronorm pan size GN2/1
- Frequency/voltage: 50Hz/220-240 V
- Stainless steel finish exterior and interior
- Plastic coated steel shelves
- Refrigerant: R290
- Lockable castor wheels
- Ambient temperatures from +16°C to +43°C



GSF652H

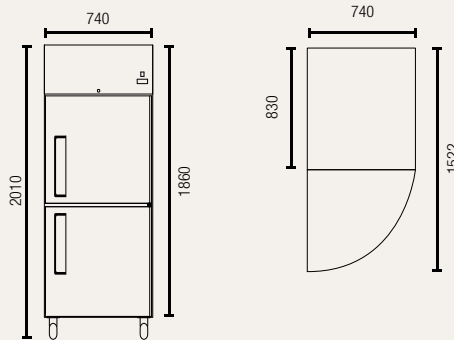

Allow min. 100mm clearance for installation, all vents must be left clear

Gross volume: 685 L

Exterior dimensions in mm: 740w x 830d x 2010h

Number of adjustable shelves: 3

Temperature set range: -18°C to -22°C

Gross/net weight: 141/126 kg

Energy consumption in 24h: 6.7 kWh

GSF1412H

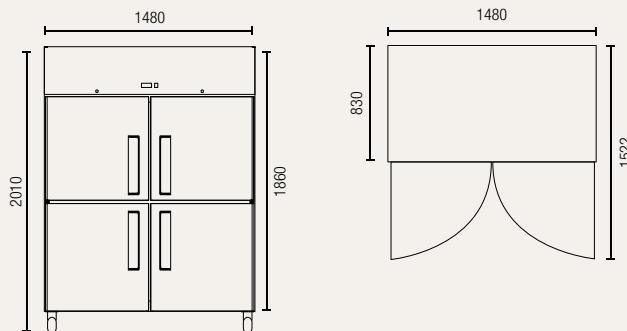

Allow min. 100mm clearance for installation, all vents must be left clear

Gross volume: 1476 L

Exterior dimensions in mm: 1480w x 830d x 2010h

Number of adjustable shelves: 6

Temperature set range: -18°C to -22°C

Gross/net weight: 226/201 kg

Energy consumption in 24h: 10.5 kWh

Food Preparation Refrigerators

Features:

- Self closing stainless steel doors with integrated handles
- Digital controller and digital temperature display
- Dynamic fan forced cooling system with automatic defrosting
- Under bench shelf to fit gastronorm pan size GN1/1
- Frequency/voltage: 50Hz/220-240 V

- Plastic coated steel shelves
- Refrigerant: R290
- Lockable castor wheels
- Ambient temperatures from +16°C to +43°C



MTC263H



* catering tubs and tub-lids not included

⚠ Allow min. 100mm clearance for installation, all vents must be left clear

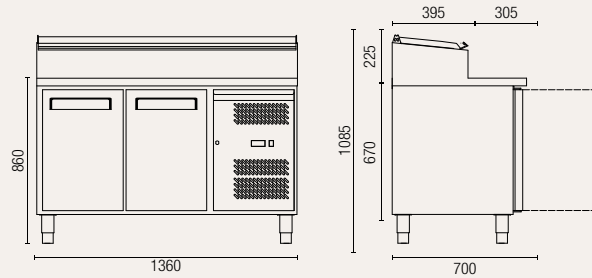

Gross volume: 282 L

Exterior dimensions in mm: 1360w x 700d x 1085h

Number of adjustable shelves: 2

Gastronorm pan size (top): 7 x GN1/3

Temperature set range: +2°C to +8°C

Gross/net weight: 131/104 kg

Preparation area material: stainless steel

Energy consumption in 24h: 3.4 kWh

MTC363H



* catering tubs and tub-lids not included

⚠ Allow min. 100mm clearance for installation, all vents must be left clear

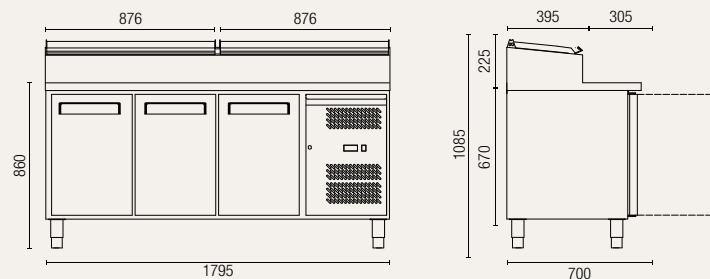

Gross volume: 417 L

Exterior dimensions in mm: 1795w x 700d x 1085h

Number of adjustable shelves: 3

Gastronorm pan size (top): 8 x GN1/3

Temperature set range: -2°C to +8°C

Gross/net weight: 161/130 kg

Preparation area material: stainless steel

Energy consumption in 24h: 4.35 kWh

Food Preparation Refrigerators

Features:

- Self closing stainless steel doors with integrated handles
- Digital controller and digital temperature display
- Dynamic fan forced cooling system with automatic defrosting
- Stainless steel finish exterior and interior

- Plastic coated steel shelves

- Refrigerant: R290

- Castor wheels

- Ambient temperatures from +16°C to +38°C



ICC260H



Plastic catering tubs included

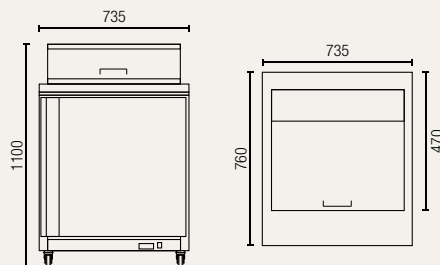

Allow min. 100mm clearance for installation, all vents must be left clear

Gross volume: 251 L

Exterior dimensions in mm: 735w x 760d x 1100h

Number of adjustable shelves: 1

Temperature set range: -2°C to +8°C

Gross/net weight: 116/85 kg

Gastronorm pan size (top): 8 x GN1/6

ICC400H



Plastic catering tubs included

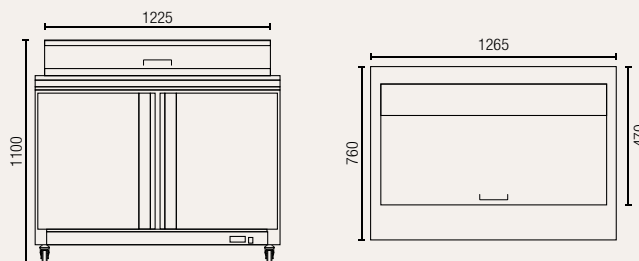

Allow min. 100mm clearance for installation, all vents must be left clear

Gross volume: 406 L

Exterior dimensions in mm: 1265w x 760d x 1100h

Number of adjustable shelves: 2

Temperature set range: -2°C to +8°C

Gross/net weight: 179/123 kg

Gastronorm pan size (top): 12 x GN1/6

ICC550H



Plastic catering tubs included

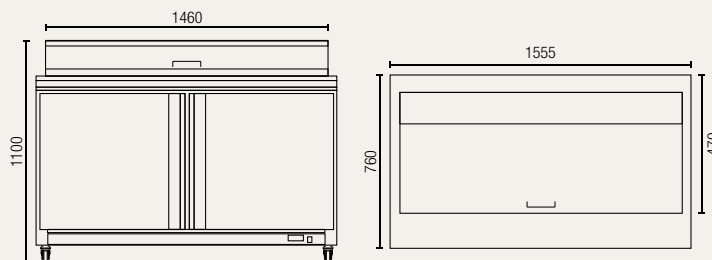

Allow min. 100mm clearance for installation, all vents must be left clear

Gross volume: 527 L

Exterior dimensions in mm: 1555w x 760d x 1100h

Number of adjustable shelves: 2

Temperature set range: -2°C to +8°C

Gross/net weight: 205/145 kg

Gastronorm pan size (top): 16 x GN1/6

Counter Top Food Preparation Refrigerators

Features:

- Dynamic fan forced cooling system with automatic defrosting
- Digital controller and digital temperature display
- Frequency/voltage: 50Hz/220-240 V
- Stainless steel and glass top cabinet finish
- To fit 150mm high GN pans
- Refrigerant: R600a
- Ambient temperatures from +16°C to +32°C



ICT1200



* catering tubs and tub-lids not included

Exterior dimensions in mm: 1200w x 395d x 450h

Gross/net weight: 60/40.5 kg

Number of GN pans: 3 x GN1/3 + 1 x GN1/2

Temperature set range: +2°C to +10°C

Energy consumption in 24h: 1.12 kWh

ICT1500

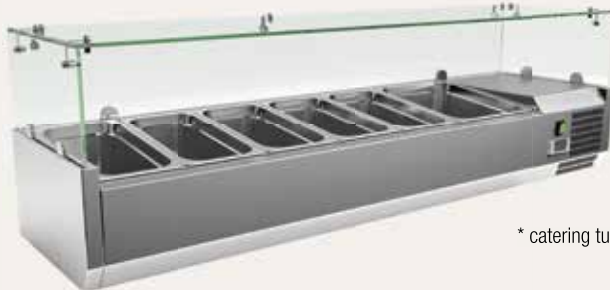

* catering tubs and tub-lids not included

Exterior dimensions in mm: 1500w x 395d x 450h

Gross/net weight: 72/48 kg

Number of GN pans: 5 x GN1/3 + 1 x GN1/2

Temperature set range: +2°C to +10°C

Energy consumption in 24h: 1.2 kWh

ICT1800



* catering tubs and tub-lids not included

Exterior dimensions in mm: 1800w x 395d x 450h

Gross/net weight: 76/50.5 kg

Number of GN pans: 8 x GN1/3

Temperature set range: +2°C to +10°C

Energy consumption in 24h: 1.25 kWh

Storage Chest Freezers - Stainless Steel Top

Features:

- White painted steel body with stainless steel lid
- Aluminium liner material
- Static cooling system with manual defrosting
- Door handle with lock
- Plastic coated steel baskets
- Frequency/voltage: 50Hz/220-240 V

- 72mm thick insulation
- Castor wheels
- Internal light
- Refrigerant: R290
- Ambient temperatures +35°C



ESS560H

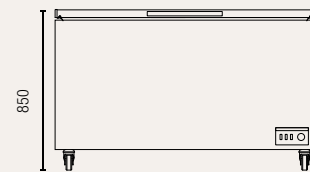
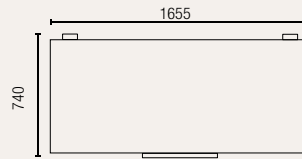

Gross volume: 488 L

Exterior dimensions in mm: 1655w x 740d x 850h

Number of baskets: 5

Temperature set range: ≤-18°C

Gross/net weight: 87/72 kg

Energy consumption in 24h: 3.1 kWh

ESS660H

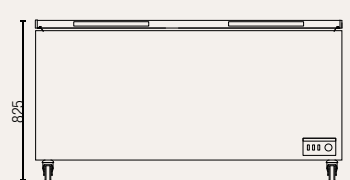
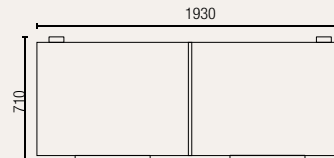
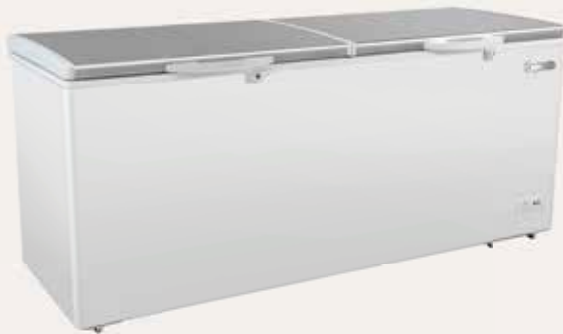

Gross volume: 561 L

Exterior dimensions in mm: 1930w x 710d x 825h

Number of baskets: 6

Temperature set range: ≤-18°C

Gross/net weight: 95/75 kg

Energy consumption in 24h: 3.6 kWh

ESS760H

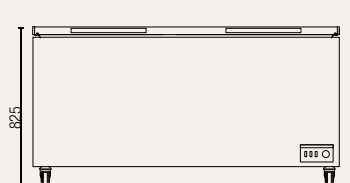
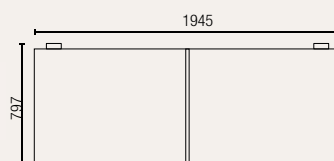
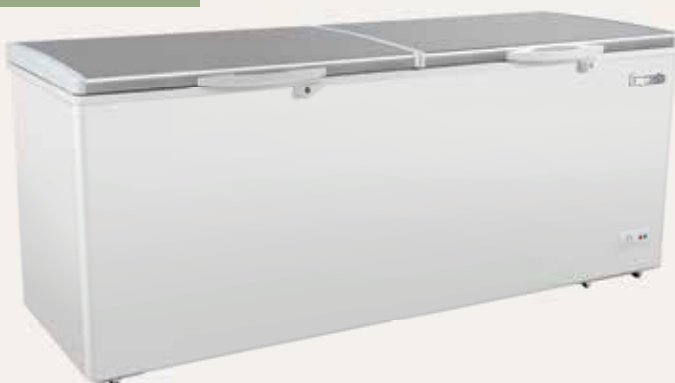

Gross volume: 662 L

Exterior dimensions in mm: 1945w x 797d x 825h

Number of baskets: 6

Temperature set range: ≤-18°C

Gross/net weight: 98/78 kg

Energy consumption in 24h: 3.7 kWh



Display Cabinets



Counter Top Display Refrigerators



Features:

- Double curved glass door (front and back) for easy stock rotation
- Lockable doors with handle
- Digital controller and digital temperature display
- Dynamic fan forced cooling system with automatic defrosting
- Frequency/voltage: 50Hz/220-240 V
- Available in black or white
- Shelf material: chrome coated steel
- Internal light
- Refrigerant: R600a
- Ambient temperatures from +16°C to +32°C

CTD78



available in
Black or
White



Double lockable curved doors

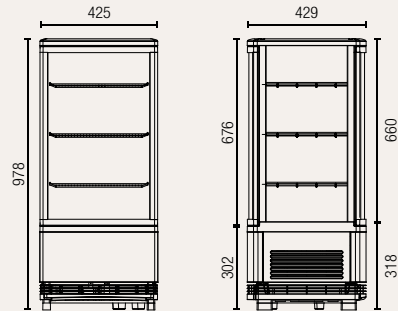

Gross volume: 86 L

Exterior dimensions in mm: 425w x 429d x 978h

Number of adjustable shelves: 3

Temperature set range: +2°C to +12°C

Gross/net weight: 39/36.5 kg

Energy consumption in 24h: 1.9kWh

CTD78LED



available in
Black or
White



Double lockable curved doors

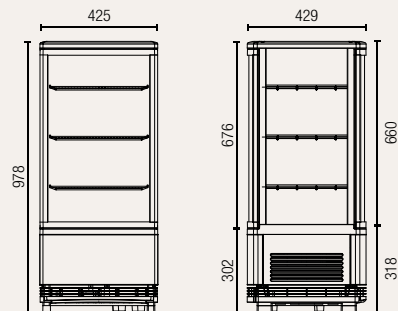

Gross volume: 86 L

Exterior dimensions in mm: 425w x 429d x 978h

Number of adjustable shelves: 3

LED strip on corners: yes

Temperature set range: +2°C to +12°C

Gross/net weight: 39/36.5 kg

Energy consumption in 24h: 1.9kWh

Upright Display Refrigerators

Features:

- Double glazed curved glass door with handle
- Digital controller and digital temperature display
- Dynamic fan forced cooling system with automatic defrosting
- Internal LED lights on corners
- Frequency/voltage: 50Hz/220-240 V
- Shelf material: chrome coated steel
- Removable top light box
- Castor wheels
- Refrigerant: R290
- Ambient temperatures from +16°C to +32°C



CTD235 Black

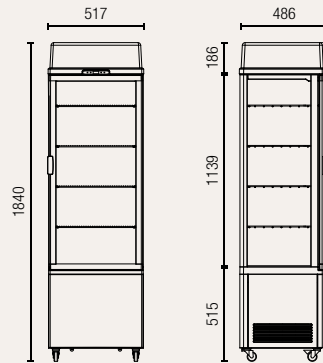

Gross volume: 235 L

Exterior dimensions in mm: 517w x 486d x 1840h

Number of adjustable shelves: 4

Temperature set range: +2°C to +12°C

Gross/net weight: 80.5/76.4 kg

Energy consumption in 24h: 5.46 kWh

CTD235 White

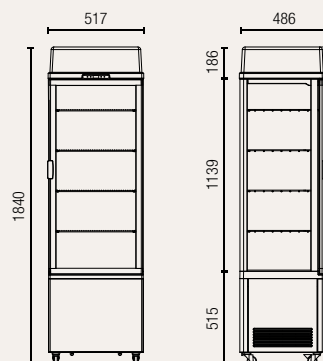

Gross volume: 235 L

Exterior dimensions in mm: 517w x 486d x 1840h

Number of adjustable shelves: 4

Temperature set range: +2°C to +12°C

Gross/net weight: 80.5/76.4 kg

Energy consumption in 24h: 5.46 kWh

Upright Display Refrigerators

Features:

- 4 sided glass for maximum display area
- Dynamic fan forced cooling system with automatic defrosting
- Digital controller and digital temperature display
- Frequency/voltage: 50Hz/220-240 V

- Lockable door
- Shelf material: plastic coated steel
- Refrigerant: R290
- Ambient temperatures from +16°C to +30°C



CTD280

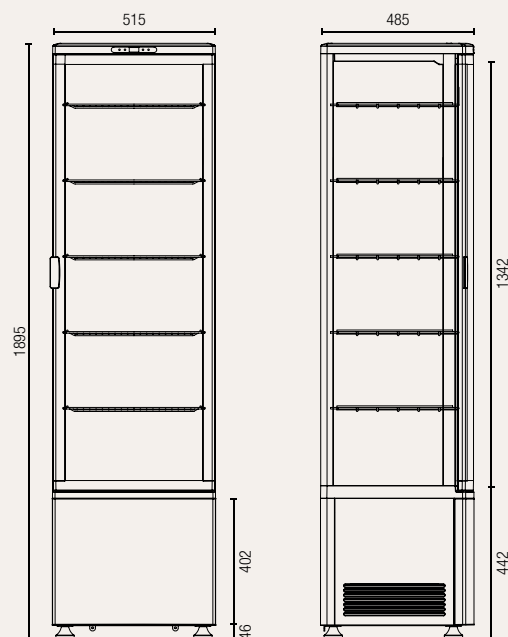

Gross volume: 280 L

Exterior dimensions in mm: 515w x 485d x 1895h

Number of adjustable shelves: 4

Temperature set range: +2°C to +12°C

Gross/net weight: 89/94.1 kg

Energy consumption in 24h: 3.28kWh

Upright Display Refrigerators

Features:

- Lockable double glazed doors with handles
- Digital controller and digital temperature display
- Dynamic fan forced cooling system with automatic defrosting
- Plastic coated steel shelves
- Frequency/voltage: 50Hz/220-240 V
- White steel external and internal finish
- LED internal light
- Castor wheels
- Refrigerant: R600a
- Ambient temperatures from +16°C to +38°C



DC400P



available in
Black or
White



Gross volume: 400 L

Exterior dimensions in mm: 606w x 620d x 2000h

Number of adjustable shelves: 4

Temperature set range: 0°C to +10°C

Gross/net weight: 98/83 kg

Energy consumption in 24h: 4 kWh

Upright Display Refrigerators

Features:

- Double glazed doors with LowE
- Digital controller and digital temperature display
- Dynamic fan forced cooling system with automatic defrosting
- Plastic coated steel shelves
- Frequency/voltage: 50Hz/220-240 V

- Prepainted steel external and internal finish
- LED internal light (2 sides + top)
- Castor wheels
- Refrigerant: R290
- Ambient temperatures from +16°C to +38°C



DC1000P



available in
Black or
White

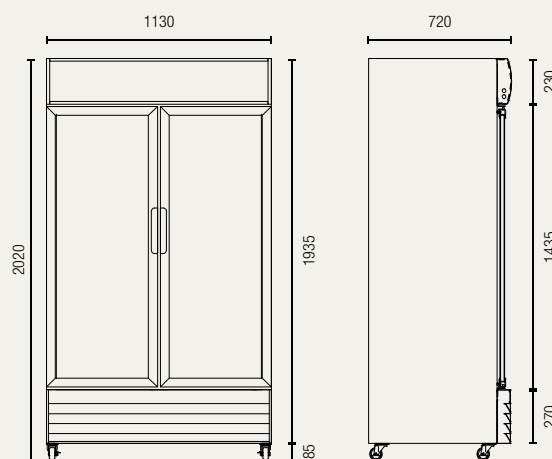

Gross volume: 1000 L

Exterior dimensions in mm: 1130w x 720d x 2020h

Number of adjustable shelves: 8

Temperature set range: 0°C to +10°C

Gross/net weight: 175/155 kg

Energy consumption in 24h: 5.6 kWh

Upright Display Refrigerators

Features:

- Double glazed doors with LowE
- Digital controller and digital temperature display
- Dynamic fan forced cooling system with automatic defrosting
- Plastic coated steel shelves
- Frequency/voltage: 50Hz/220-240 V
- Prepainted steel external and internal finish
- LED internal light (2 sides + top)
- Castor wheels
- Refrigerant: R290
- Ambient temperatures from +16°C to +38°C



DC700

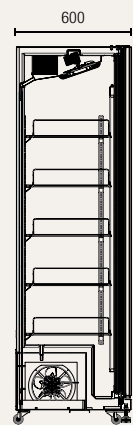
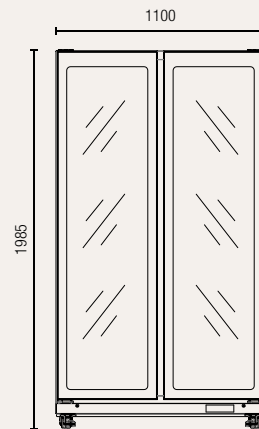

Gross volume: 710 L

Exterior dimensions in mm: 1100w x 600d x 1985h

Number of adjustable shelves: 10

Temperature set range: 0°C to +10°C

Gross/net weight: 195/160 kg

Energy consumption in 24h: 4.1 kWh

Upright Display Refrigerators

Features:

- Double glazed doors with LowE
- Digital controller and digital temperature display
- Dynamic fan forced cooling system with automatic defrosting
- Plastic coated steel shelves
- Frequency/voltage: 50Hz/220-240 V
- Prepainted steel external and internal finish
- LED internal light (2 sides + top)
- Castor wheels
- Refrigerant: R290
- Ambient temperatures from +16°C to +38°C



DC1100

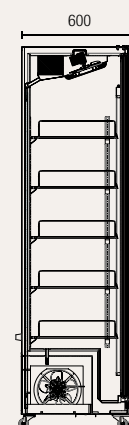
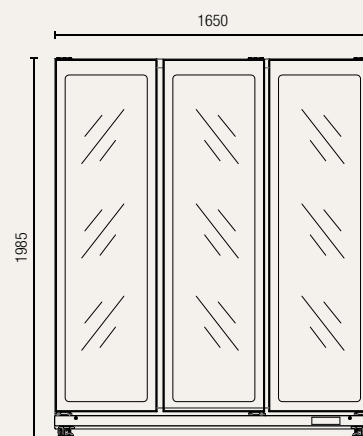
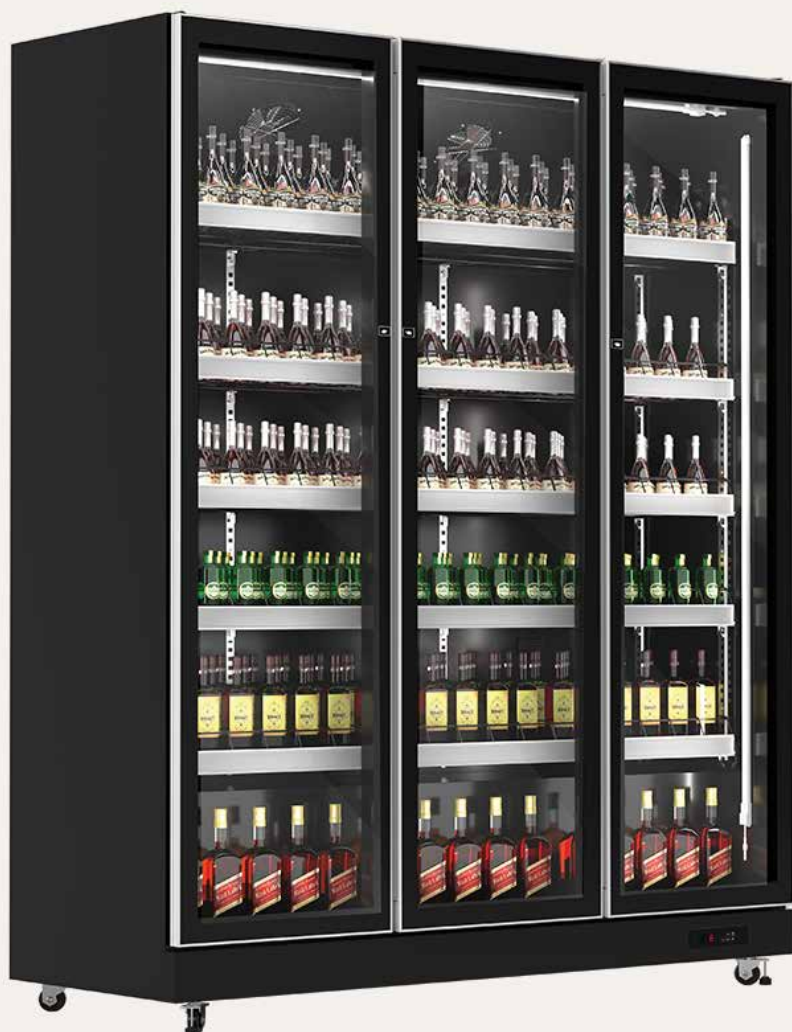

Gross volume: 1100 L

Exterior dimensions in mm: 1650w x 600d x 1985h

Number of adjustable shelves: 15

Temperature set range: 0°C to +10°C

Gross/net weight: 230/220 kg

Energy consumption in 24h: 5.4 kWh

Supermarket Display Chillers

Features:

- Low E tempered glass door with integrated handle
- Digital controller and digital temperature display
- Dynamic fan forced cooling system with automatic defrosting
- LED internal light
- Frequency/voltage: 50Hz/220 V
- Powder coated steel cabinet finish
- Plastic coated steel shelves
- Castor wheels
- Refrigerant: R290
- Ambient temperatures from +18°C to +38°C



SMC1600

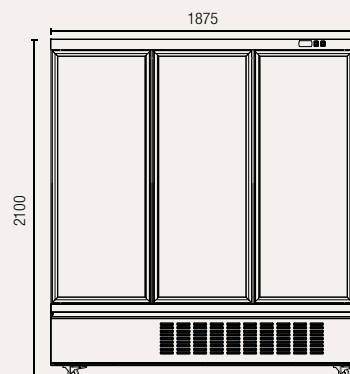
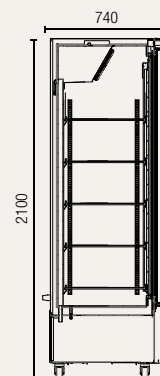

Gross volume: 1665 L

Exterior dimensions in mm: 1875w x 740d x 2100h

Number of adjustable shelves: 15

Temperature set range: 0°C to +10°C

Gross/net weight: 284/245 kg

Energy consumption in 24h: 8.28 kWh

Backbar Display Refrigerators - Swing Door

Features:

- Lockable double glazed glass doors
- Digital controller and digital temperature display
- Dynamic fan forced cooling system with automatic defrosting
- Black steel external finish and aluminium internal finish
- Frequency/voltage: 50Hz/220-240 V

- Shelf material: chrome coated steel
- LED internal light
- Refrigerant: R600a
- Ambient temperatures from +16°C to +38°C



UBC210

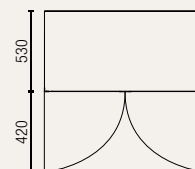
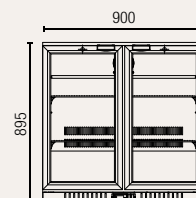

Gross volume: 219 L

Exterior dimensions in mm: 900w x 530d x 895h

Number of adjustable shelves: 4

Temperature set range: 0°C to +10°C

Gross/net weight: 65/59 kg

Energy consumption in 24h: 1.8 kWh

UBC330

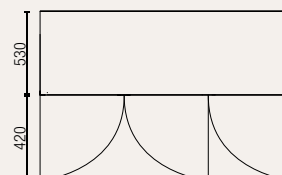
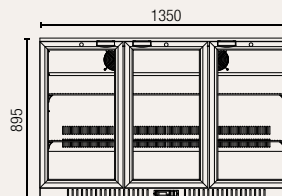

Gross volume: 339 L

Exterior dimensions in mm: 1350w x 530d x 895h

Number of adjustable shelves: 6

Temperature set range: 0°C to +10°C

Gross/net weight: 84/80 kg

Energy consumption in 24h: 2.1 kWh

Backbar Display Refrigerators - Swing Door

Features:

- Lockable double glazed glass doors
- Digital controller and digital temperature display
- Dynamic fan forced cooling system with automatic defrosting
- Black steel external finish and aluminium internal finish
- Frequency/voltage: 50Hz/220-240 V
- Shelf material: chrome coated steel
- LED internal light
- Refrigerant: R600a
- Ambient temperatures from +16°C to +38°C



UBC210L



LOWER HEIGHT

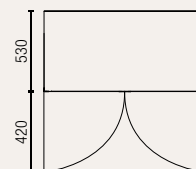
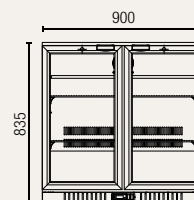

Gross volume: 199 L

Exterior dimensions in mm: 900w x 530d x 835h

Number of adjustable shelves: 4

Temperature set range: 0°C to +10°C

Gross/net weight: 61/57 kg

Energy consumption in 24h: 1.8 kWh

UBC330L



LOWER HEIGHT

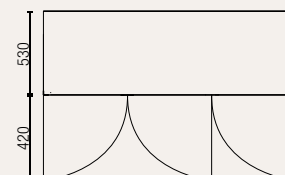
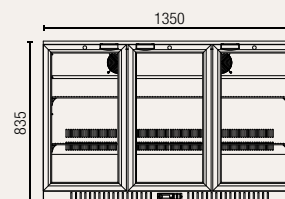

Gross volume: 308 L

Exterior dimensions in mm: 1350w x 530d x 835h

Number of adjustable shelves: 6

Temperature set range: 0°C to +10°C

Gross/net weight: 82/78 kg

Energy consumption in 24h: 2.1 kWh

Backbar Display Refrigerators - Sliding Door

Features:

- Lockable double glazed glass doors
- Digital controller and digital temperature display
- Dynamic fan forced cooling system with automatic defrosting
- Black steel external finish and aluminium internal finish
- Frequency/voltage: 50Hz/220-240 V

- Shelf material: chrome coated steel
- LED internal light
- Refrigerant: R600a
- Ambient temperatures from +16°C to +38°C



UBC210S

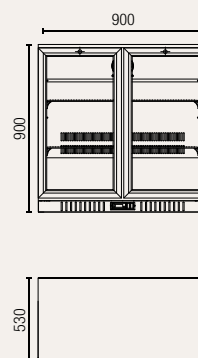

Gross volume: 208 L

Exterior dimensions in mm: 900w x 530d x 900h

Number of adjustable shelves: 4

Temperature set range: 0°C to +10°C

Gross/net weight: 72/62 kg

Energy consumption in 24h: 1.9 kWh

UBC330S

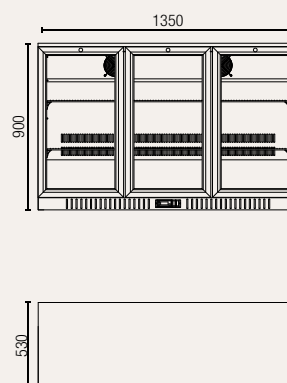

Gross volume: 330 L

Exterior dimensions in mm: 1350w x 530d x 900h

Number of adjustable shelves: 6

Temperature set range: 0°C to +10°C

Gross/net weight: 90/80 kg

Energy consumption in 24h: 2.5 kWh

Backbar Display Refrigerators - Sliding Door

Features:

- Lockable double glazed glass doors
- Digital controller and digital temperature display
- Dynamic fan forced cooling system with automatic defrosting
- Black steel external finish and aluminium internal finish
- Frequency/voltage: 50Hz/220-240 V
- Shelf material: chrome coated steel
- LED internal light
- Refrigerant: R600a
- Ambient temperatures from +16°C to +38°C



UBC210SL



LOWER HEIGHT

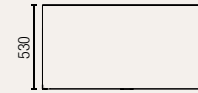
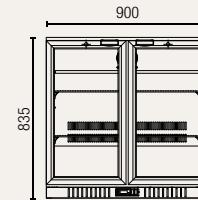

Gross volume: 199 L

Exterior dimensions in mm: 900w x 530d x 835h

Number of adjustable shelves: 4

Temperature set range: 0°C to +10°C

Gross/net weight: 61/57 kg

Energy consumption in 24h: 1.8 kWh

UBC330SL



LOWER HEIGHT

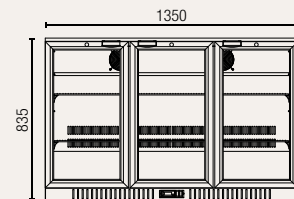

Gross volume: 308 L

Exterior dimensions in mm: 1350w x 530d x 835h

Number of adjustable shelves: 6

Temperature set range: 0°C to +10°C

Gross/net weight: 82/78 kg

Energy consumption in 24h: 2.1 kWh

Backbar Display Refrigerators - Swing Door

Features:

- Double glazed self closing glass doors
- Digital controller and digital temperature display
- Dynamic fan forced cooling system with automatic defrosting
- Black steel external and internal finish
- Frequency/voltage: 50Hz/220-240 V
- Shelf material: perforated stainless steel
- LED internal light
- Refrigerant: R290
- Ambient temperatures from +16°C to +38°C



UBC630

NEW
PRODUCT

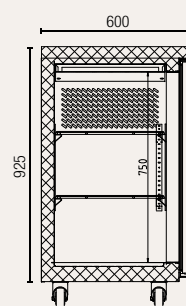
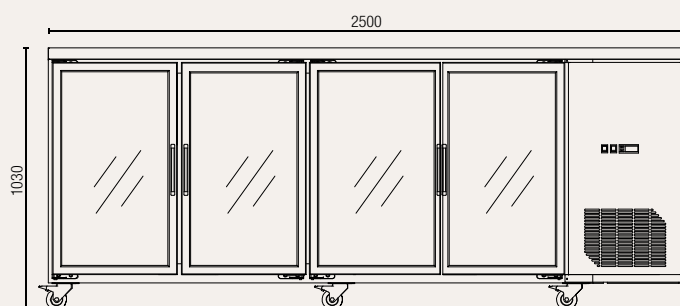

Gross volume: 700 L

Exterior dimensions in mm: 2500w x 600d x 1030h

Number of adjustable shelves: 8

Temperature set range: +0°C to +10°C

Gross/net weight: 170/140 kg

Energy consumption in 24h: 4.1kWh

Cake Display Refrigerators

Features:

- Digital temperature display and electronic controller
- Dynamic fan forced cooling system with auto defrosting
- Double layer glass for maximum insulation
- Black stainless steel finish
- Shelf material: frosted glass

- Sliding door for easy access
- LED internal light
- Refrigerant: R290
- Frequency/voltage: 50Hz/230 V
- Ambient temperatures from +16°C to +30°C



CDR209

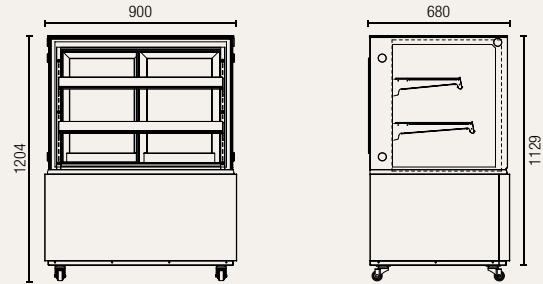

Gross volume: 300 L

Exterior dimensions in mm: 900w x 680d x 1204h

Number of adjustable shelves: 2

Temperature set range: +2°C to +6°C

Gross/net weight: 166/130 kg

Energy consumption in 24h: 6.122 kWh

CDR212

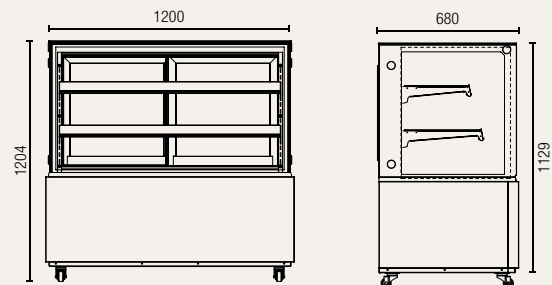

Gross volume: 410 L

Exterior dimensions in mm: 1200w x 680d x 1204h

Number of adjustable shelves: 2

Temperature set range: +2°C to +6°C

Gross/net weight: 200/156.5 kg

Energy consumption in 24h: 6.829 kWh

CDR215

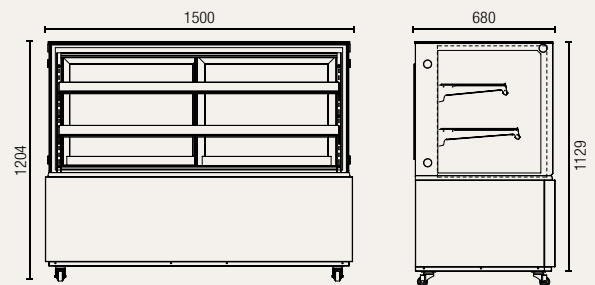

Gross volume: 520 L

Exterior dimensions in mm: 1500w x 680d x 1204h

Number of adjustable shelves: 2

Temperature set range: +2°C to +6°C

Gross/net weight: 233.5/183 kg

Energy consumption in 24h: 8.401 kWh

Cake Display Refrigerators

Features:

- Digital temperature display and electronic controller
- Dynamic fan forced cooling system with auto defrosting
- Double layer glass for maximum insulation
- Black stainless steel finish
- Shelf material: frosted glass

- Sliding door for easy access
- LED internal light
- Refrigerant: R290
- Frequency/voltage: 50Hz/230 V
- Ambient temperatures from +16°C to +30°C



CDR309

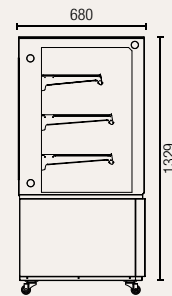
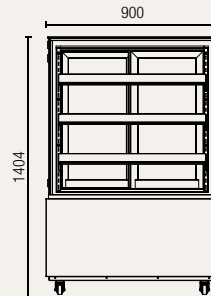

Gross volume: 390 L

Exterior dimensions in mm: 900w x 680d x 1404h

Number of adjustable shelves: 3

Temperature set range: +2°C to +6°C

Gross/net weight: 192/148 kg

Energy consumption in 24h: 7.105 kWh

CDR312

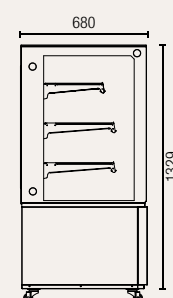
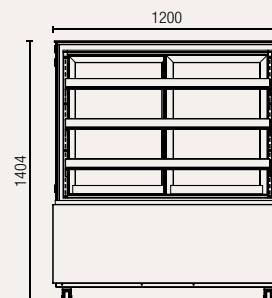

Gross volume: 540 L

Exterior dimensions in mm: 1200w x 680d x 1404h

Number of adjustable shelves: 3

Temperature set range: +2°C to +6°C

Gross/net weight: 229.5/180 kg

Energy consumption in 24h: 8.374 kWh

CDR315

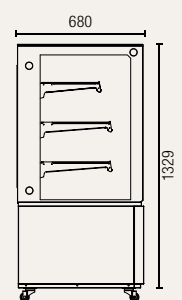
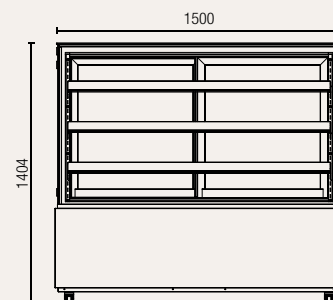

Gross volume: 680 L

Exterior dimensions in mm: 1500w x 680d x 1404h

Number of adjustable shelves: 3

Temperature set range: +2°C to +6°C

Gross/net weight: 269.5/211 kg

Energy consumption in 24h: 10.935 kWh

Cake Display Refrigerators

Features:

- Digital temperature display and electronic controller
- Dynamic fan forced cooling system with auto defrosting
- Double layer glass for maximum insulation
- Dark grey stainless steel finish
- Shelf material: frosted glass

- Sliding door for easy access
- LED internal light
- Refrigerant: R290
- Frequency/voltage: 50Hz/220-240 V
- Ambient temperatures from +16°C to +30°C



CDS209



available in
Dark Grey or
Black

**RUN OUT
MODEL**
Limited Stock

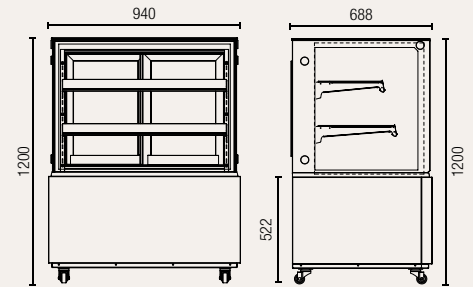

Gross volume: 270 L

Exterior dimensions in mm: 940w x 688d x 1200h

Number of adjustable shelves: 2

Temperature set range: 0°C to +12°C

Gross/net weight: 154/135 kg

Energy consumption in 24h: 4.30 kWh

CDS212



available in
Dark Grey or
Black

**RUN OUT
MODEL**
Limited Stock

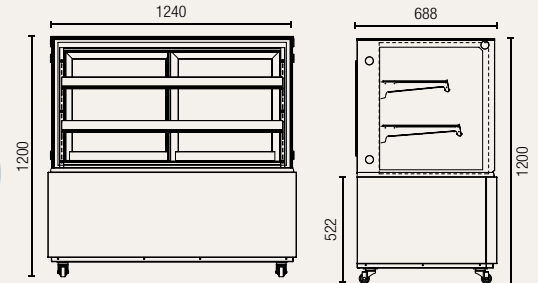

Gross volume: 370 L

Exterior dimensions in mm: 1240w x 688d x 1200h

Number of adjustable shelves: 2

Temperature set range: 0°C to +12°C

Gross/net weight: 188/155 kg

Energy consumption in 24h: 5.56 kWh

CDS215



available in
Dark Grey or
Black

**RUN OUT
MODEL**
Limited Stock

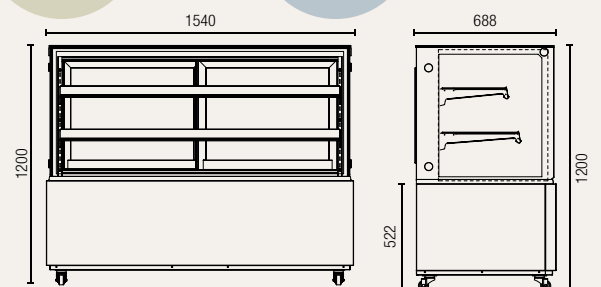

Gross volume: 470 L

Exterior dimensions in mm: 1540w x 688d x 1200h

Number of adjustable shelves: 2

Temperature set range: 0°C to +12°C

Gross/net weight: 230/182 kg

Energy consumption in 24h: 5.58 kWh

Cake Display Refrigerators

Features:

- Digital temperature display and electronic controller
- Dynamic fan forced cooling system with auto defrosting
- Double layer glass for maximum insulation
- Dark grey stainless steel finish
- Shelf material: frosted glass
- Sliding door for easy access
- LED internal light
- Refrigerant: R290
- Frequency/voltage: 50Hz/220-240 V
- Ambient temperatures from +16°C to +30°C



CDS309



available in
Dark Grey or
Black

**RUN OUT
MODEL**
Limited Stock

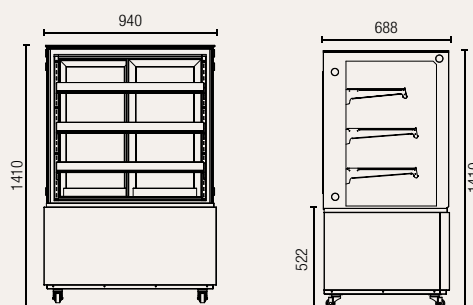

Gross volume: 390 L

Exterior dimensions in mm: 940w x 688d x 1410h

Number of adjustable shelves: 3

Temperature set range: 0°C to +12°C

Gross/net weight: 190/162 kg

Energy consumption in 24h: 4.42 kWh

Counter Top Cake Display Refrigerators

Features:

- Digital temperature display and electronic controller
- Dynamic fan forced cooling system
- Sliding door for easy access
- Frequency/voltage: 50Hz/220-240 V

- Shelf material: chrome coated steel
- Top LED internal light
- Refrigerant: R600a
- Ambient temperatures from +16°C to +32°C



CTC120

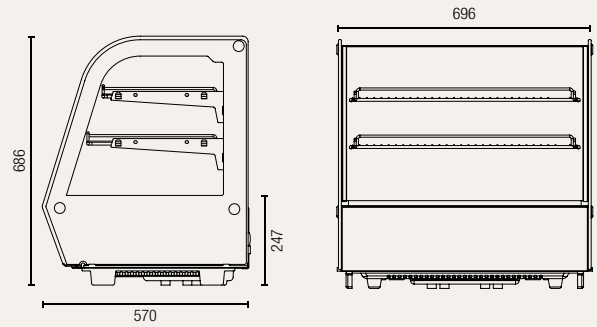

Gross volume: 120 L

Exterior dimensions in mm: 710w x 575d x 686h

Number of adjustable shelves: 2

Temperature set range: 0°C to +12°C

Gross/net weight: 66/64 kg

Energy consumption in 24h: 2.75 kWh

CTC160

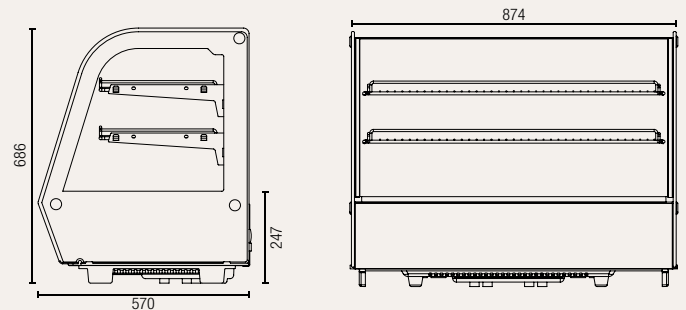

Gross volume: 160 L

Exterior dimensions in mm: 890w x 575d x 686h

Number of adjustable shelves: 2

Temperature set range: 0°C to +12°C

Gross/net weight: 74/71 kg

Energy consumption in 24h: 2.85 kWh

Counter Top Cake Display Refrigerators

Features:

- Digital temperature display and electronic controller
- Dynamic fan forced cooling system
- Sliding door for easy access
- Frequency/voltage: 50Hz/220-240 V

- Shelf material: chrome coated steel
- Top LED internal light
- Refrigerant: R600a
- Ambient temperatures from +16°C to +32°C



CTC120S

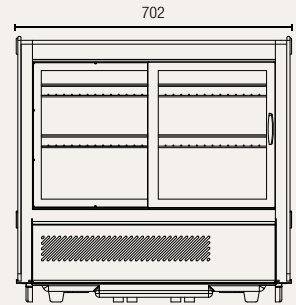
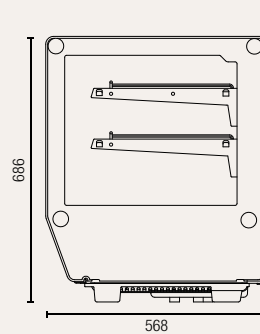

Gross volume: 120 L

Exterior dimensions in mm: 702w x 568d x 686h

Number of adjustable shelves: 2

Temperature set range: 0°C to +12°C

Gross/net weight: 60/57 kg

Energy consumption in 24h: 2.75 kWh

CTC160S

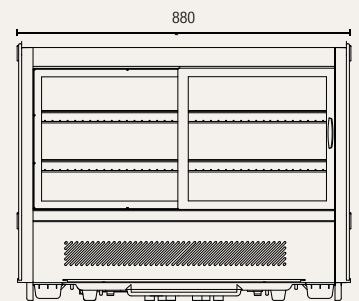
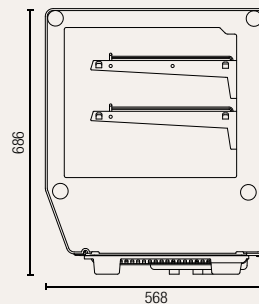

Gross volume: 160 L

Exterior dimensions in mm: 880w x 568d x 686h

Number of adjustable shelves: 2

Temperature set range: 0°C to +12°C

Gross/net weight: 69/66 kg

Energy consumption in 24h: 2.78 kWh

Ambient Cake Display

Features:

- Attractive design
- Black alluminum frame
- Sliding glass doors with handle
- Easy to assemble

CD48



**NEW
PRODUCT**

Gross Volume: 48L

Dimension in mm: 920w x 330d x 200h

CD65



**NEW
PRODUCT**

Gross Volume: 65L

Dimension in mm: 550w x 398d x 381h

CD68



**NEW
PRODUCT**

Gross Volume: 68L

Dimension in mm: 1200w x 330d x 200h

CD120



**NEW
PRODUCT**

Gross Volume: 120L

Dimension in mm: 920w x 398d x 381h

Ambient Cake Display

Features:

- Attractive design
- Fully assembled
- Easy to clean laminate base
- Rubber feet



- Elegant timber look thick laminate base



- Door hinge designed to hold door open



- Stainless steel look door handle with stopper

Available in 3 attractive colours:



- Elegant Walnut



- Woodgrain Black



- Natural Oak

CD35



CD35-O



CD35-W



CD35-B

RUN OUT MODEL

Limited Stock



Gross Volume: 35L

Dimension in mm: 554w x 361d x 305h

- Square glass
- Single tier
- Double opening to the front and back

CD45



CD45-O



CD45-W



CD45-B



Gross Volume: 45L

Dimension in mm: 554w x 376d x 370h

- Curved glass
- Double tier

CD50



CD50-O



CD50-W



CD50-B



Gross Volume: 50L

Dimension in mm: 554w x 361d x 370h

- Square glass
- Double tier
- Double opening to the front and back

Display Freezers



Curved Glass Display Chest Freezers

Features:

- Analog temperature display and controller
- Static cooling system
- Sliding curved glass doors with lock
- Removable rubber bumper on the engine side (30mm) for ventilation purpose
- Frequency/voltage: 50Hz/220-240 V
- Plastic coated steel baskets
- Castor wheels
- Powder coated steel exterior dan interior
- 70 mm thick insulation
- Ambient temperatures from +16°C to +38°C

SD151



Gross volume: 151 L

Exterior dimensions in mm: 584w x 694d x 850h

Number of baskets: 2

Refrigerant: R134a

Temperature set range: $\leq -18^{\circ}\text{C}$

Gross/net weight: 55/48 kg

Energy consumption in 24h: 1.6 kWh

SD400



Gross volume: 374 L

Exterior dimensions in mm: 1240w x 694d x 850h

Number of baskets: 5

Refrigerant: R134a

Temperature set range: $\leq -18^{\circ}\text{C}$

Gross/net weight: 82/71 kg

Energy consumption in 24h: 2.0 kWh

SD575K



Gross volume: 575 L

Exterior dimensions in mm: 1684w x 694d x 850h

Number of baskets: 7

Refrigerant: R404a

Temperature set range: $\leq -18^{\circ}\text{C}$

Gross/net weight: 108/90 kg

Energy consumption in 24h: 3.7 kWh

Flat Glass Display Chest Freezers

Features:

- Analog temperature display and controller
- Static cooling system
- Sliding flat glass doors with lock
- Removable rubber bumper on the engine side (30mm) for ventilation purpose
- Frequency/voltage: 50Hz/220-240 V
- Plastic coated steel baskets
- Castor wheels
- Powder coated steel exterior dan interior
- 70 mm thick insulation
- Ambient temperatures from +16°C to +38°C

SD450



Gross volume: 390 L

Exterior dimensions in mm: 1314w x 694d x 830h

Number of baskets: 4

Refrigerant: R134a

Temperature set range: $\leq -18^{\circ}\text{C}$

Gross/net weight: 81/73 kg

Energy consumption in 24h: 3.25 kWh

SD650



Gross volume: 566 L

Exterior dimensions in mm: 1799w x 694d x 830h

Number of baskets: 6

Refrigerant: R404a

Temperature set range: $\leq -18^{\circ}\text{C}$

Gross/net weight: 99/89 kg

Energy consumption in 24h: 4.6 kWh

Ice Cream Scooping Freezers

Features:

- Analog temperature display and controller
- Static cooling system
- Sliding curved glass doors with lock
- Rear perspex sliding doors
- Removable rubber bumper on the engine side (30mm) for ventilation purpose
- 70 mm thick insulation
- Frequency/voltage: 50Hz/220-240 V
- 5L stainless steel tubs included
- Castor wheels
- Powder coated steel exterior dan interior
- Front light box and internal LED lights
- Mid glass shelf included (not pictured)
- Scoop washer included
- Ambient temperatures from +16°C to +38°C

SD325S2



5L stainless steel tubs included



Rear door for easy storage access



Scoop washer included

Gross volume: 325 L

Exterior dimensions in mm: 1080w x 838d x 1245h

Number 5L tubs: 6

Rear door storage access: yes

Temperature set range: $\leq -18^{\circ}\text{C}$

Gross/net weight: 138/109 kg

Energy consumption in 24h: 2.3 kWh

Refrigerant: R134a

SD415S2



5L stainless steel tubs included



Rear door for easy storage access



Scoop washer included

Gross volume: 415 L

Exterior dimensions in mm: 1350w x 838d x 1245h

Number 5L tubs: 9

Rear door storage access: yes

Temperature set range: $\leq -18^{\circ}\text{C}$

Gross/net weight: 162/123 kg

Energy consumption in 24h: 3.1 kWh

Refrigerant: R134a

SD575S2



5L stainless steel tubs included



Rear door for easy storage access



Scoop washer included

Gross volume: 575 L

Exterior dimensions in mm: 1720w x 838d x 1245h

Number 5L tubs: 12

Rear door storage access: yes

Temperature set range: $\leq -18^{\circ}\text{C}$

Gross/net weight: 199/152 kg

Energy consumption in 24h: 4.5 kWh

Refrigerant: R404a

Gelato Freezers

Features:

- Digital temperature display and electronic controller
- Dynamic cooling system with auto defrosting
- Sliding flat glass doors
- Frequency/voltage: 50Hz/220-240 V

- Refrigerant: R290
- Castor wheels
- 60 mm thick insulation
- Ambient temperatures from +16°C to +32°C



IC16T

**NEW
PRODUCT**

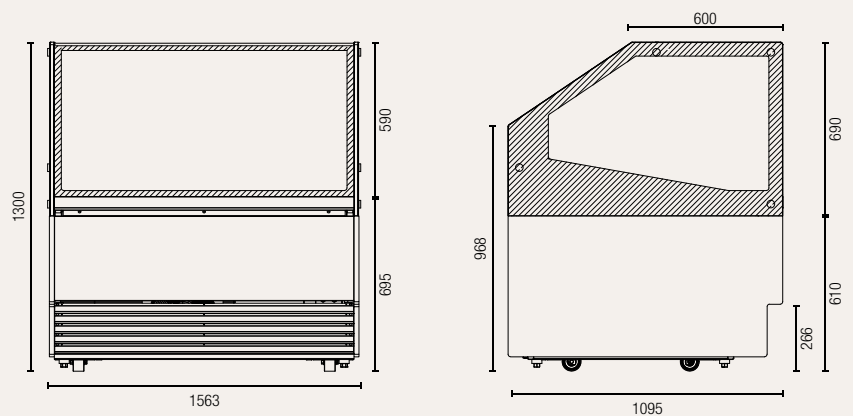

Gross volume: 754 L

Exterior dimensions in mm: 1563w x 1095d x 1300h

Number 5L tubs hold: 16 (tubs not included)

Temperature set range: -16°C -18°C

Gross/net weight: 397/302 kg

Energy consumption in 24h: 27.4 kWh

Supermarket Island Freezers

Features:

- Digital temperature display and controller
- Static cooling system
- Auto defrosting system
- Sliding curved glass doors
- Frequency/voltage: 50Hz/220-240 V
- Plastic coated steel baskets
- Castor wheels
- LED internal light
- Powder coated steel exterior dan interior
- 80 mm thick insulation
- Drain tube integrated



HR-21H



**RUN OUT
MODEL**
Limited Stock

Gross volume: 826 L

Exterior dimensions in mm: 2105 x 816d x 850h

Number of baskets: 8

Temperature set range: $\leq -18^{\circ}\text{C}$

Gross/net weight: 135/120 kg

Nominal power consumption: 6 W

Vaccine Refrigerators



Vaccine Refrigerators

Features:

- Digital controller with digital temperature display
- Temperature data logger included
- Dynamic fan forced cooling system with automatic defrosting
- Double glazed glass door
- White External and Interior Finish
- Internal LED light
- Frequency/voltage: 50Hz/220-240 V
- Leveling adjustable feet
- QCPP approved
- Plastic coated steel shelves
- Battery backup controller
- Refrigerant: R600a
- Ambient temperatures from +16°C to +32°C



MV30

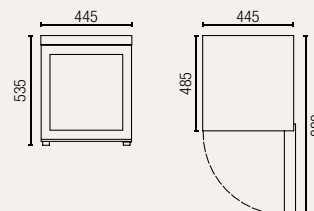

Gross/Net volume: 30/29 L

Exterior dimensions in mm: 445w x 485d x 535h

Number of shelves: 3

Max. noise level: 50 dB

Temperature range: +2°C to +8°C

Gross/net weight: 29/27 kg

Energy consumption in 24h: 0.8 kWh

MV60

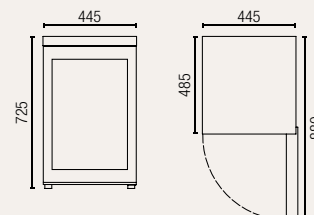
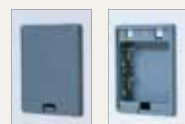

Gross/Net volume: 62/59 L

Exterior dimensions in mm: 445w x 485d x 725h

Number of shelves: 4

Max. noise level: 50 dB

Temperature range: +2°C to +8°C

Gross/net weight: 33/31 kg

Energy consumption in 24h: 0.8 kWh

MV150

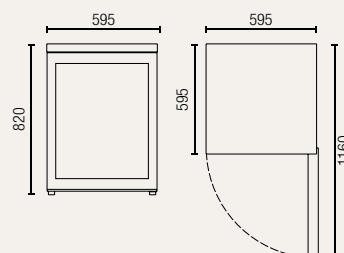
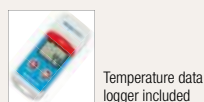

Gross/Net volume: 148/145 L

Exterior dimensions in mm: 595w x 595d x 820h

Number of shelves: 4

Max. noise level: 50 dB

Temperature range: +2°C to +8°C

Gross/net weight: 45/42 kg

Energy consumption in 24h: 1.35 kWh

Vaccine Refrigerators

Features:

- Digital controller with digital temperature display
- Temperature data logger included
- Dynamic fan forced cooling system with automatic defrosting
- Double glazed glass door
- White External and Interior Finish
- Internal LED light
- Frequency/voltage: 50Hz/220-240 V
- Leveling adjustable feet
- QCPP approved
- Plastic coated steel shelves
- Battery backup controller
- Refrigerant: R600a
- Ambient temperatures from +16°C to +32°C



MV300



Temperature data logger included



Battery backup for controller in case of power outage

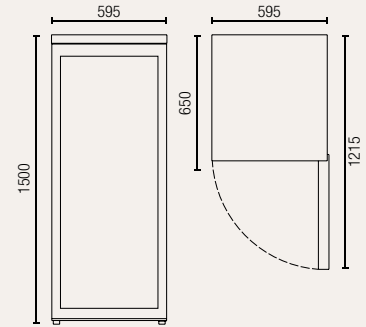

Gross/Net volume: 308/300 L

Exterior dimensions in mm: 595w x 650d x 1500h

Number of shelves: 8

Max. noise level: 55 dB

Temperature range: +2°C to +8°C

Gross/net weight: 78/72 kg

Energy consumption in 24h: 2.9 kWh

MV400



Temperature data logger included



Battery backup for controller in case of power outage

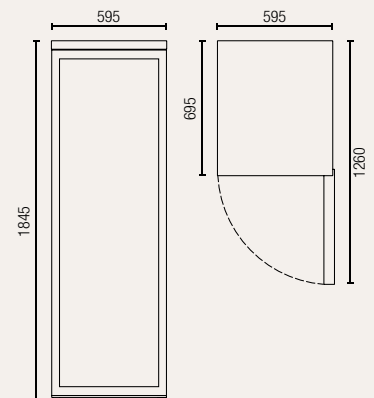

Gross/Net volume: 408/400 L

Exterior dimensions in mm: 595w x 695d x 1845h

Number of shelves: 8

Max. noise level: 65 dB

Temperature range: +2°C to +8°C

Gross/net weight: 92/84 kg

Energy consumption in 24h: 3.1 kWh